

**H.V.
DISCONNECTING
SWITCHES
POWER FUSES
AIR LOAD BREAK
SWITCHES
VT, CT**

**Disconnecting switches
V3 type**

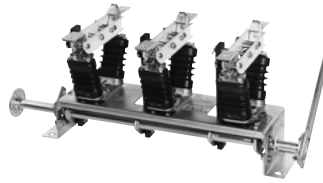

**Air load break switches
LB, LBS and RF types**

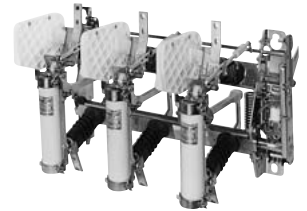

**Disconnecting switches
V type**

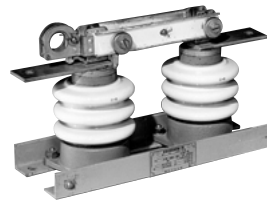

**Instrument transformers
CT**



**Power fuses
HF type**



**Instrument transformers
VT**



**Power fuses
SCF and HF types**



**Instrument transformers
ZCT**



**Air load break switches
LB, LBS and RF types**



**HIGH
VOLTAGE
EQUIPMENT
Up to 36kV**

**INDIVIDUAL
CATALOG**

from D&C CATALOG 19th Edition
Revised

11

D & C CATALOG DIGEST INDEX

Individual catalog No.	LOW VOLTAGE PRODUCTS Up to 600 Volts
------------------------	--------------------------------------

01	Magnetic Contactors and Starters Thermal Overload Relays, Solid-state Contactors
-----------	---

02	DUO series Manual Motor Starters and Contactors Combination Starters
-----------	--

03	Industrial Relays, Industrial Control Relays Annunciator Relay Unit, Time Delay Relays Electronic Counters
-----------	--

04	Pushbuttons, Selector Switches, Pilot Lights Rotary Switches, Cam Type Selector Switches Panel Switches, Terminal Blocks, Testing Terminals
-----------	---

05	AS-Interface, Limit Switches Proximity Switches Photoelectric Switches
-----------	--

06	Molded Case Circuit Breakers
-----------	------------------------------

07	Earth Leakage Circuit Breakers Earth Leakage Protective Relays
-----------	---

08	Circuit Protectors Low Voltage Current-Limiting Fuses Air Circuit Breakers
-----------	--

09	Measuring Instruments, Arresters, Transducers Power Factor Controllers Power Monitoring Equipment (F-MPC)
-----------	---

10	AC Power Regulators Noise Suppression Filters Control Power Transformers
-----------	--

HIGH VOLTAGE PRODUCTS Up to 36kV

11	Disconnecting Switches, Power Fuses Air Load Break Switches Instrument Transformers — VT, CT
-----------	--

12	Vacuum Circuit Breakers, Vacuum Magnetic Contactors Protective Relays
-----------	--

11

H.V. Disconnecting switches Power fuses, Air load break switches Instrument transformers



	Page
Disconnecting Switches	
V, V3, RF type	11/1
Dimensions	11/3
Operating mechanism	11/9
Power Fuses	
General information	11/10
Applications	11/11
General purpose fuses SCF, HF, SCH	11/17
Back-up fuses JR, HF	11/18
Characteristic curves	11/19
Dimensions	11/22
Air Load Break Switches	
General information	11/26
Accessories/LB type	11/28
Accessories/LBS type	11/29
Dimensions	11/31
Instrument Transformers	
VT, CT	
General information	11/37
Types and ratings	11/39
Dimensions	11/42
ZCT, EVT, special purpose CT	
General information	11/46
Specifications	11/47
Dimensions	11/48

MINIMUM ORDERS

Orders amounting to **less than ¥10,000** net per order will be charged as ¥10,000 net per order plus freight and other charges.

WEIGHTS AND DIMENSIONS

Weights and dimensions appearing in this catalog are the best information available at the time of going to press.

FUJI ELECTRIC FA has a policy of continuous product improvement, and design changes may make this information out of date.

Please confirm such details before planning actual construction.

INFORMATION IN THIS CATALOG IS SUBJECT TO CHANGE WITHOUT NOTICE.

■ Description

Rated voltage: 7.2 – 36kV

Rated current: Up to 4000 Amps

Indoor use

FUJI high voltage disconnecting switches comprise the V and RF types. The small size and lightness of the V type disconnecting switches make them highly suitable for cubicle use. They make use of FUJI's specially designed coil spring, a line-contact and ball contact (RF type) system which gives them a high efficient operation without overheating.

V type disconnecting switches are not provided with latches but their design will not permit them to be opened by magnetic force. Switches provided with latches can also be supplied upon request.

■ Features

- 7.2/12/24/36kV, 200 Amps to 4000 Amps
- Withstand large momentary current flow
- Excellent contact performance
- Compact and light in weight
- Heavy-duty construction
- Stick-operated/gang-operated/motor operated types

■ Ordering information

Specify the following:

1. Type number
2. Rated voltage and current
3. Connection system
4. Operation system
5. Auxiliary contact arrangement

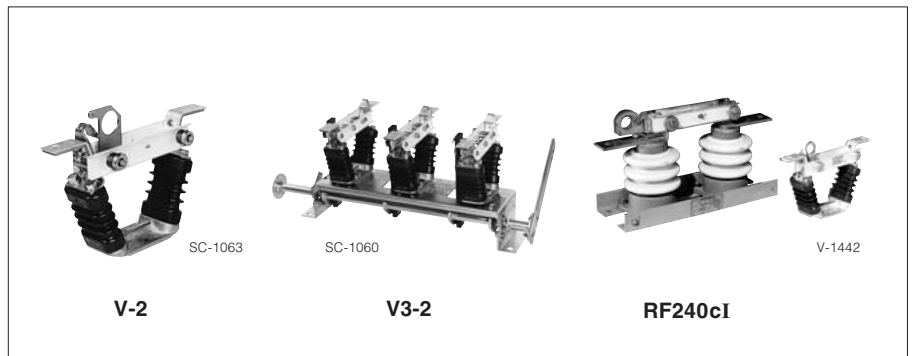

■ Type number nomenclature

● V type/7.2kV

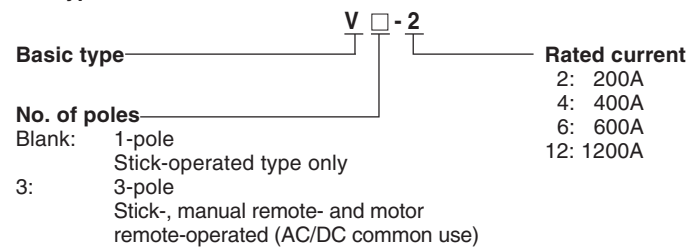

● V type/12kV, 24kV

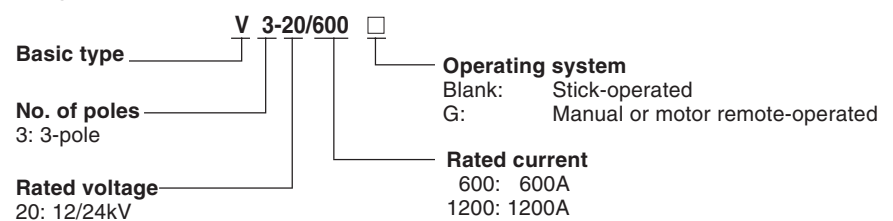

● RF240 type

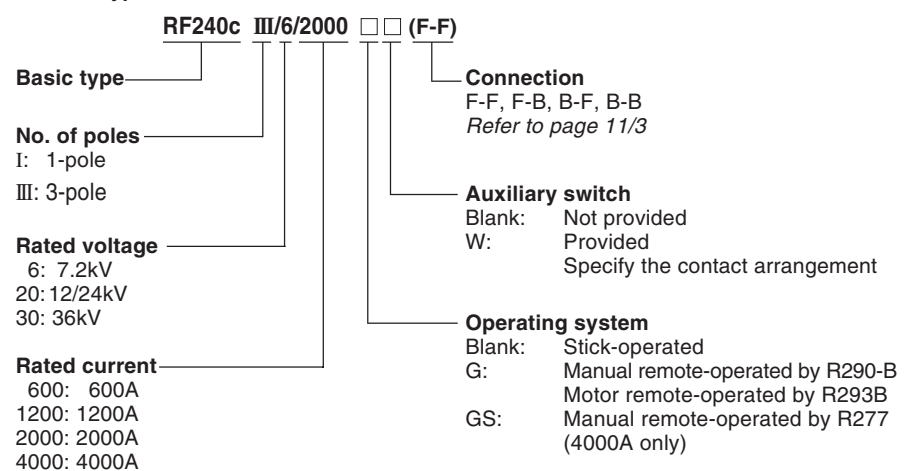

H.V. Distribution Equipment

Disconnecting switches

V and RF-type

■ Specifications

No. of poles	Ratings Voltage (kV)	Current (A)	Short-time withstand current (kA)	Connection	Auxiliary switch	Type	Ordering code	Mass (kg)		
1	3.6/7.2	200	12.5 (1 sec) *3	Common use	Not available	V-2 *2	HV3V-200*2	1.2		
		400	12.5 (1 sec) *3			V-4 *2	HV3V-400*2	1.2		
		600	12.5 (1 sec) *3			V-6 *2	HV3V-600*2	1.8		
		1200	25 (2 sec) *4			V-12*2	HV3V-12X*2	2.8		
3	3.6/7.2	200	12.5 (1 sec) *3	Common use	2NO+2NC sold separately	V3-2	HV3W-200	10		
		400	12.5 (1 sec) *3			V3-4	HV3W-400	10		
		600	12.5 (1 sec) *3			V3-6	HV3W-600	11		
		1200	25 (2 sec) *4			V3-12	HV3W-12X	14		
1	3.6/7.2	2000	32 (2 sec)	F-F B-B B-F F-B	Not available	RF240ci/6/2000(F-F)	HV3A3-20XA	22		
						RF240ci/6/2000(B-B)	HV3A3-20XB	55		
3	3.6/7.2	2000	32 (2 sec)	F-F B-B B-F F-B	2NO+2NC to *1 6NO+6NC available on request	RF240cIII/6/2000(F-F)	HV3B3-20XA■*1	75		
						RF240cIII/6/2000(B-B)	HV3B3-20XB■*1	170		
1	3.6/7.2	4000	44 (2 sec)	F-F	Not available	RF240ci/6/4000(F-F)	HV3A4-40XA	35		
						RF240cIII/6/4000(F-F)	HV3B4-40XA■*3	120		
1	12/24	600	22 (2 sec)	F-F F-B B-F B-B	Not available	RF240ci/20/600(F-F)	HV3A1-600A	27		
						RF240ci/20/600(F-B)	HV3A1-600C	33		
						RF240ci/20/600(B-F)	HV3A1-600D	33		
						RF240ci/20/600(B-B)	HV3A1-600B	35		
3	12/24	1200	27 (2 sec)	F-F F-B B-F B-B	Not available	RF240ci/20/1200(F-F)	HV3A2-12XA	33		
						RF240ci/20/1200(F-B)	HV3A2-12XC	36		
						RF240ci/20/1200(B-F)	HV3A2-12XD	36		
						RF240ci/20/1200(B-B)	HV3A2-12XB	41		
1	12/24	2000	32 (2 sec)	F-F F-B B-F B-B	Not available	RF240ci/20/2000(F-F)	HV3A3-20XA	32		
						RF240ci/20/2000(F-B)	HV3A3-20XC	62		
						RF240ci/20/2000(B-F)	HV3A3-20XD	62		
						RF240ci/20/2000(B-B)	HV3A3-20XB	70		
12/24	4000	44 (2 sec)	F-F	Not available	Not available	RF240ci/20/4000(F-F)	HV3A4-40XA	70		
						RF240cIII/20/4000(F-F)	HV3B4-40XA■*3	170		
3	12/24	600	22 (2 sec)	Common use	2NO+2NC sold separately	V3-20/600	HV7W-600	40		
						1200	27 (2 sec)	V3-20/1200	HV7W-12X	45
		2000	32 (2 sec)			RF240cIII/20/2000(F-F)	HV3B3-20XA■*1	130		
						RF240cIII/20/2000(F-B)	HV3B3-20XC■*1	140		
12/24	4000	44 (2 sec)	F-F	Not available	RF240cIII/20/2000(B-F)	HV3B3-20XD■*1	140			
					RF240cIII/20/2000(B-B)	HV3B3-20XB■*1	150			
1	36	600	22 (2 sec)	F-F	Not available	RF240ci/30/600	HV3A1-600A	34		
						1200	27 (2 sec)	RF240ci/30/1200	HV3A2-12XA	40
						2000	32 (2 sec)	RF240ci/30/2000	HV3A3-20XA	48
						3	36	600	22 (2 sec)	F-F
1200	27 (2 sec)	2000	32 (2 sec)	F-F	Not available	RF240cIII/30/1200	HV3B2-12XA■*1	150		
						RF240cIII/30/2000	HV3B3-20XA■*1	180		

Note: *1 Auxiliary switch (contact arrangement 2NO+2NC to 6NO+6NC) is available on your request (3-pole only), in this case replace the ■ mark by W and specify required contact arrangement as follow.

2NO + 2NC : W=2A2B, 3NO + 3NC: W=3A3B, 4NO + 4NC: W=4A4B, 6NO + 6NC: W=6A6B

*2 When requiring V type with mechanical latch, specify type VS (example VS-2). (Specify L in ordering code.)

*3 This conforms to JIS C4606

*4 This conforms to JEC-2310

■ Auxiliary switches

3-pole V-type disconnecting switches can be fitted with auxiliary switches. The AUX-1 auxiliary switch kits, which are sold separately can easily be fitted on side. In the case of 3-pole RF type disconnecting switches if you order auxiliary switches they will be fitted at

the FUJI factory before shipment. When ordering make sure that "W" is suffixed to the type number.

Type	Contact	Use with
AUX-1	2NO+2NC 100/110V DC 15A 200/220V AC 15A	V3-2, V3-4, V3-6, V3-12 V3-20

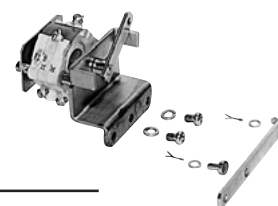

SE-1953

H.V. Distribution Equipment

Disconnecting switches

V and RF-type

■ Technical data

Type	No. of poles	Rated voltage (kV)	Dielectric strength (AC rms 1 min.) (kV)		Impulse (1.2 × 50μs) (kV)	
			To ground	Between poles	To ground	Between poles
V RF240cI/6	1	7.2	22	35	60	70
V3 RF240cIII/6	3	7.2	22	35	60	70
RF240cI/20	1	12/24	50	80	125	145
V3-20 RF240cIII/20	3	12/24	50	80	125	145
RF240cI/30	1	36	70	110	170	195
RF240cIII/30	3	36	70	110	170	195

■ Connection

Type	V, V3	RF240			
	Connection	F-F	B-B	B-F	F-B

■ Dimensions, mm

V-2, 4

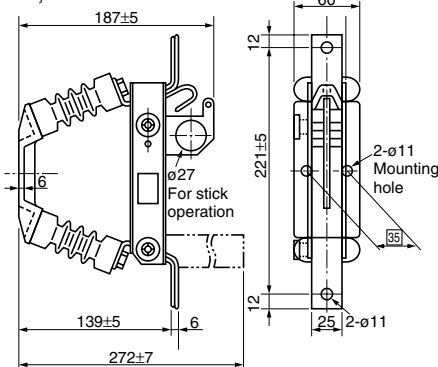

V-6

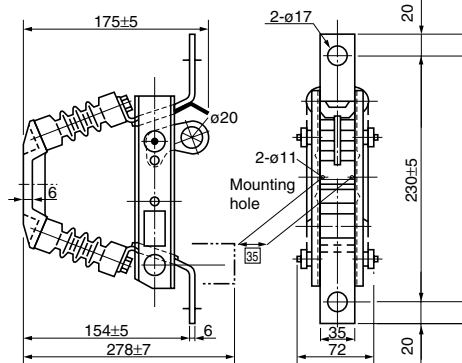

V-12

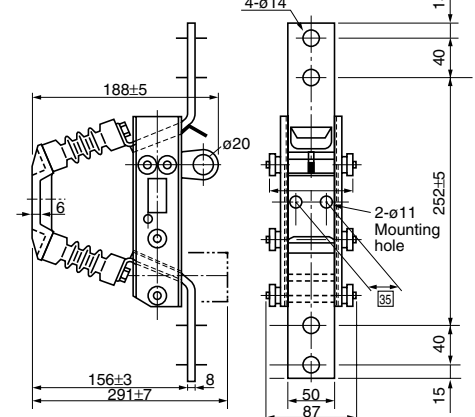

■ Ordering code system, type V

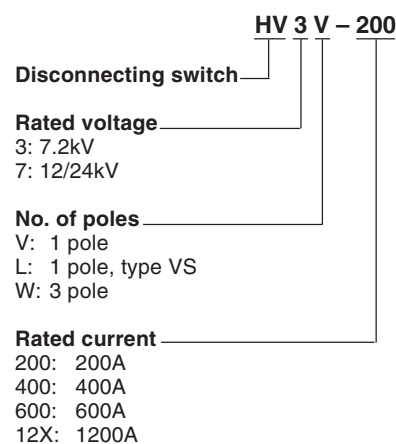

■ Ordering code system, type RF

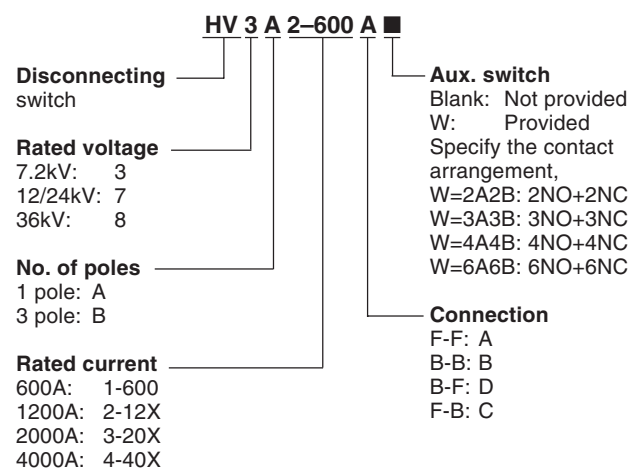

H.V. Distribution Equipment

Disconnecting switches

RF type

■ Dimensions, mm

RF240cI/20, 30/600 (F-F)

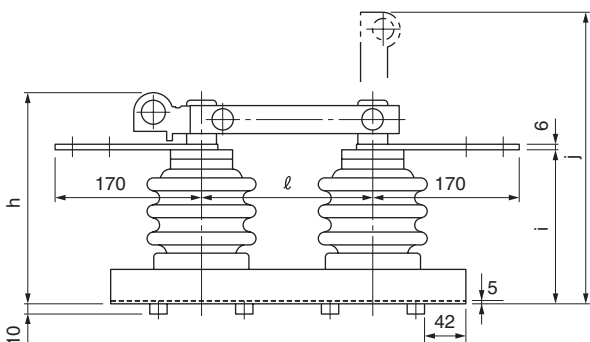
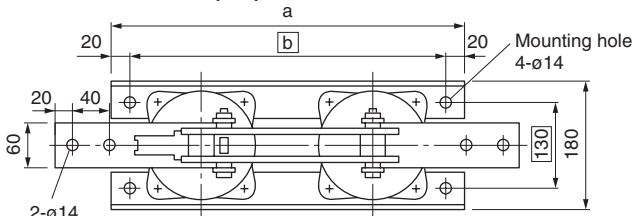

Type	a	b	h	i	j	l
RF240cI/20/600	545	505	335	269	685	300
RF240cI/30/600	645	605	432	360	889	410

RF240cI/20, 30/1200 (F-F)

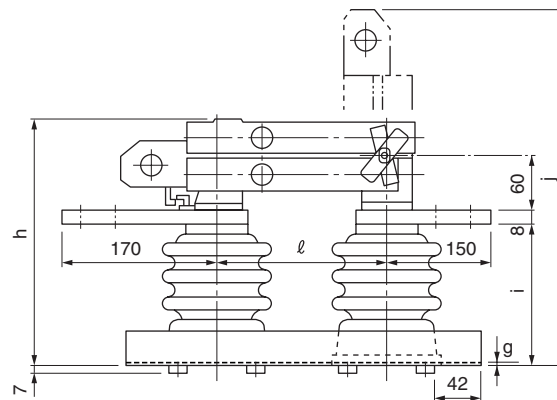
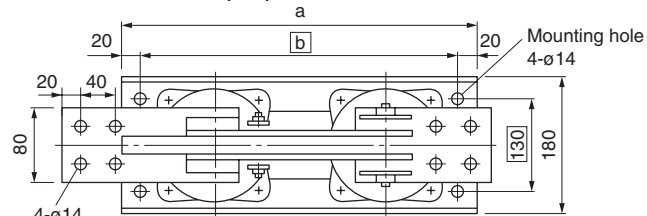

Type	a	b	h	i	j	l	g
RF240cI/20/1200	545	505	376	260	723	300	5
RF240cI/30/1200	645	605	466	350	923	410	6

RF240cI/6 – 30/2000 (F-F)

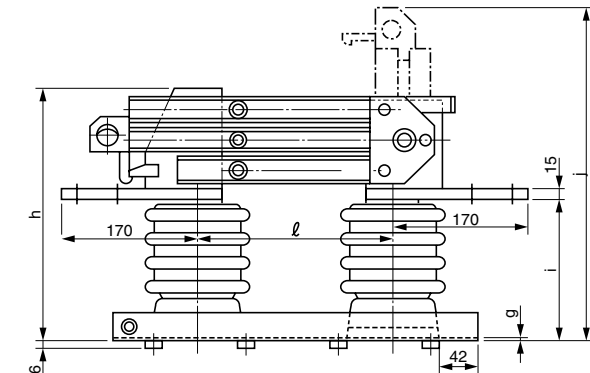
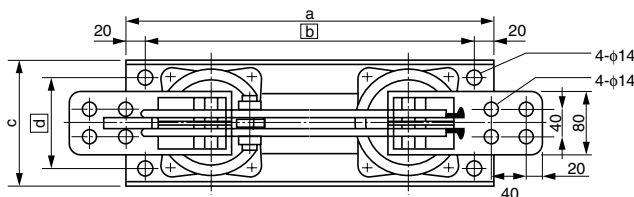

Type	a	b	c	d	h	i	j	l	g
RF240cI/6/2000	390	350	139	95	305	155	570	190	5
RF240cI/20/2000	535	495	180	130	410	261	786	300	6
RF240cI/30/2000	645	605	180	130	500	351	986	410	6

RF240cI/6, 20/4000 (F-F)

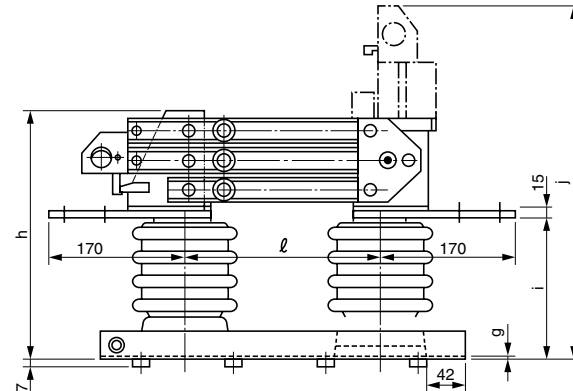
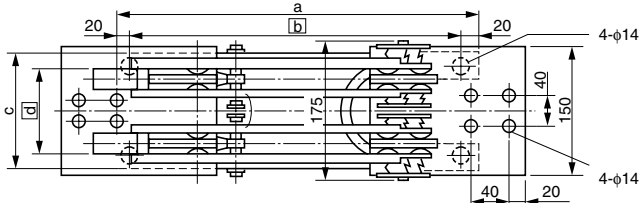

Type	a	b	c	d	h	i	j	l	g
RF240cI/6/4000	390	350	139	95	305	155	570	190	5
RF240cI/20/4000	535	495	180	130	411	261	786	300	6

■ Dimensions, mm
Gang-operating — V3 type
V3-2, V3-4

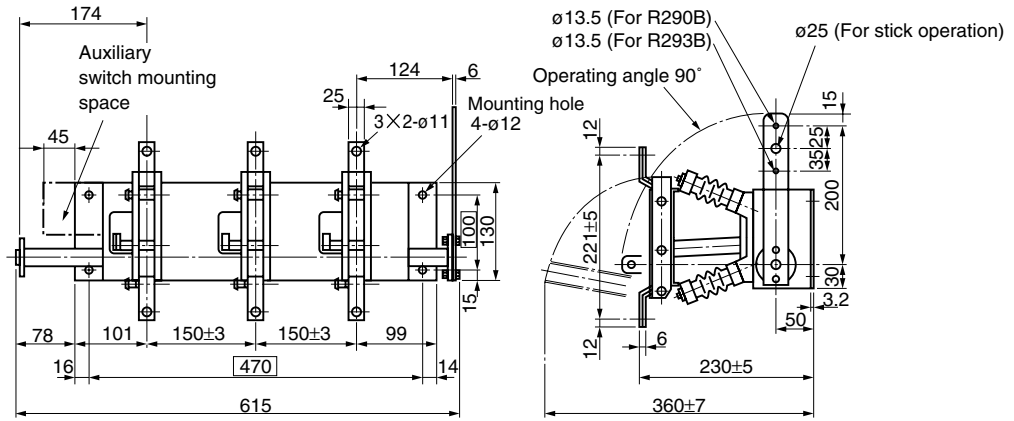

V3-6

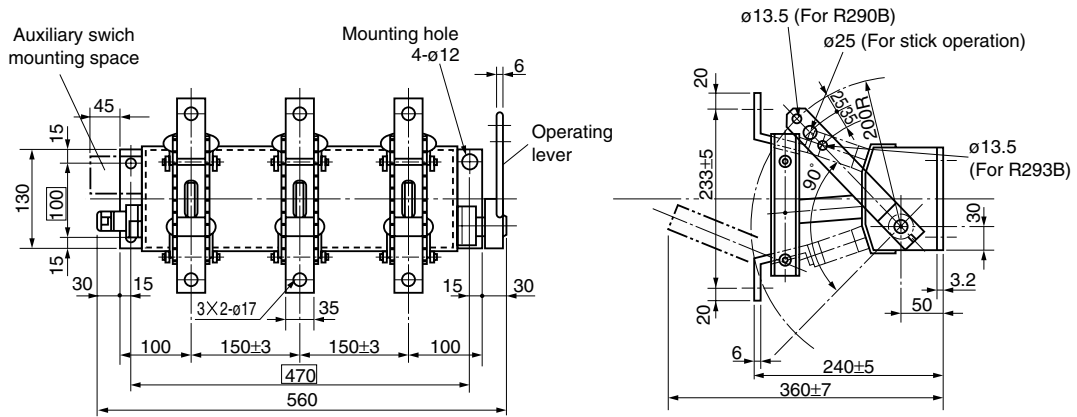

V3-12

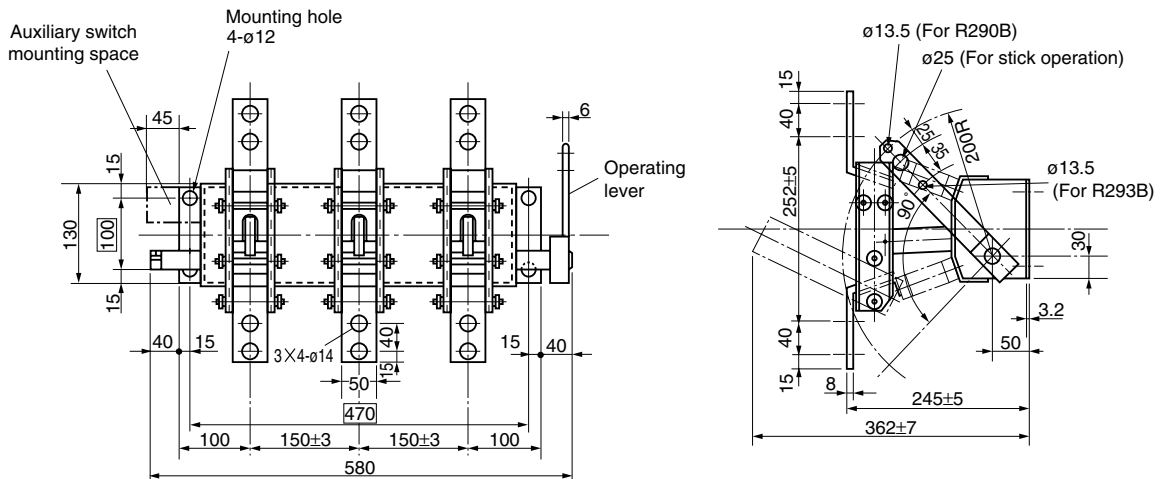

Note : □ : Mounting hole dimensions

H.V. Distribution Equipment

Disconnecting switches

RF type

■ Dimensions, mm
V3-20/600

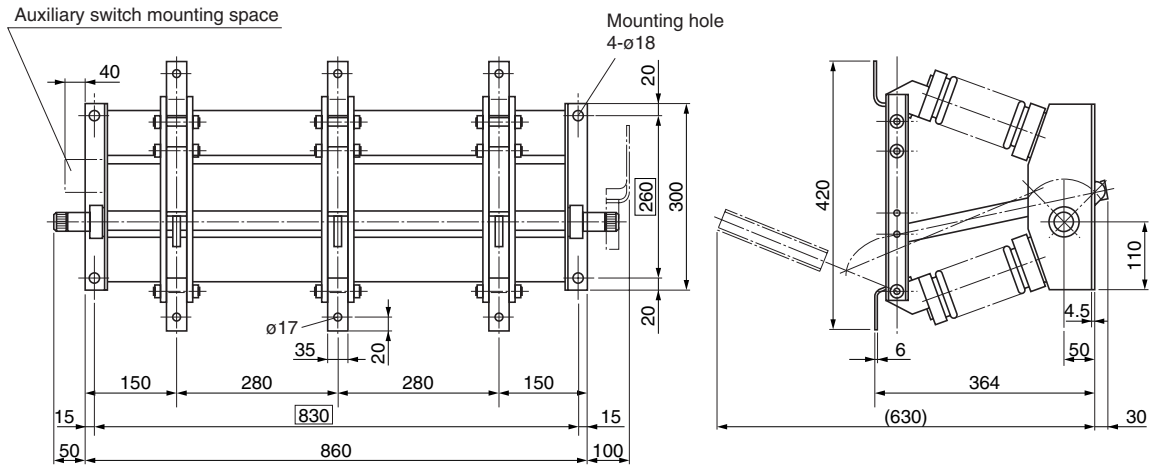

V3-20/1200

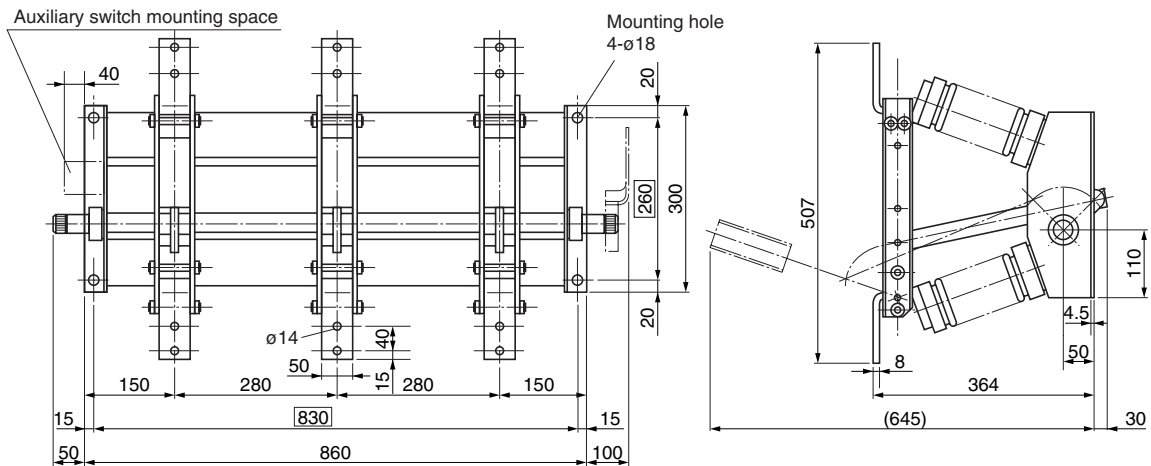

RF240cIII/30/600 (F-F)

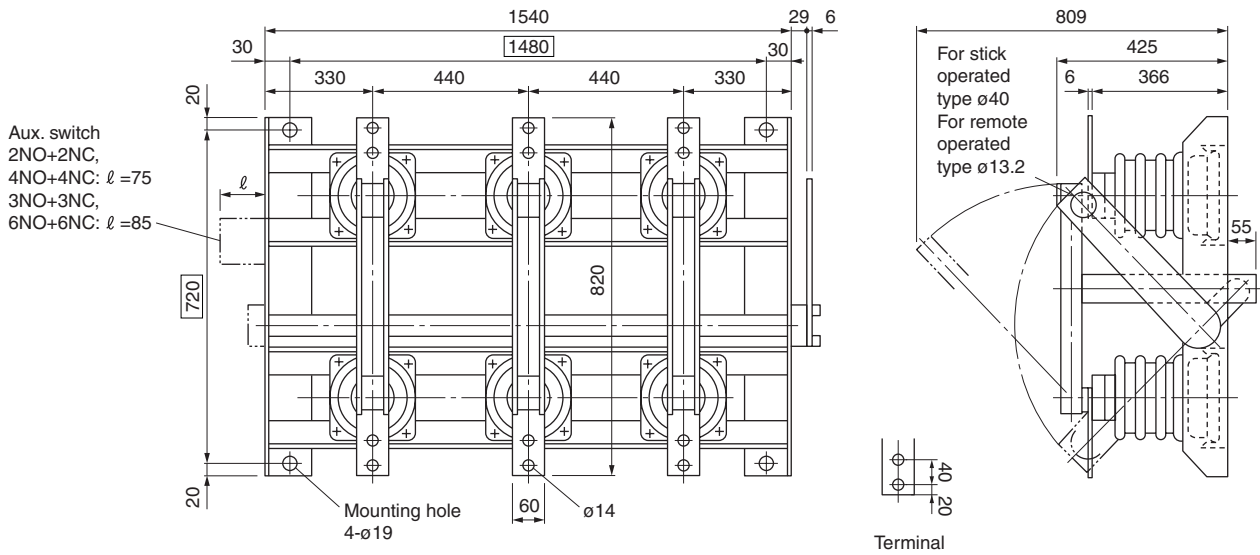

RF240cIII/20, 30/1200 (F-F)

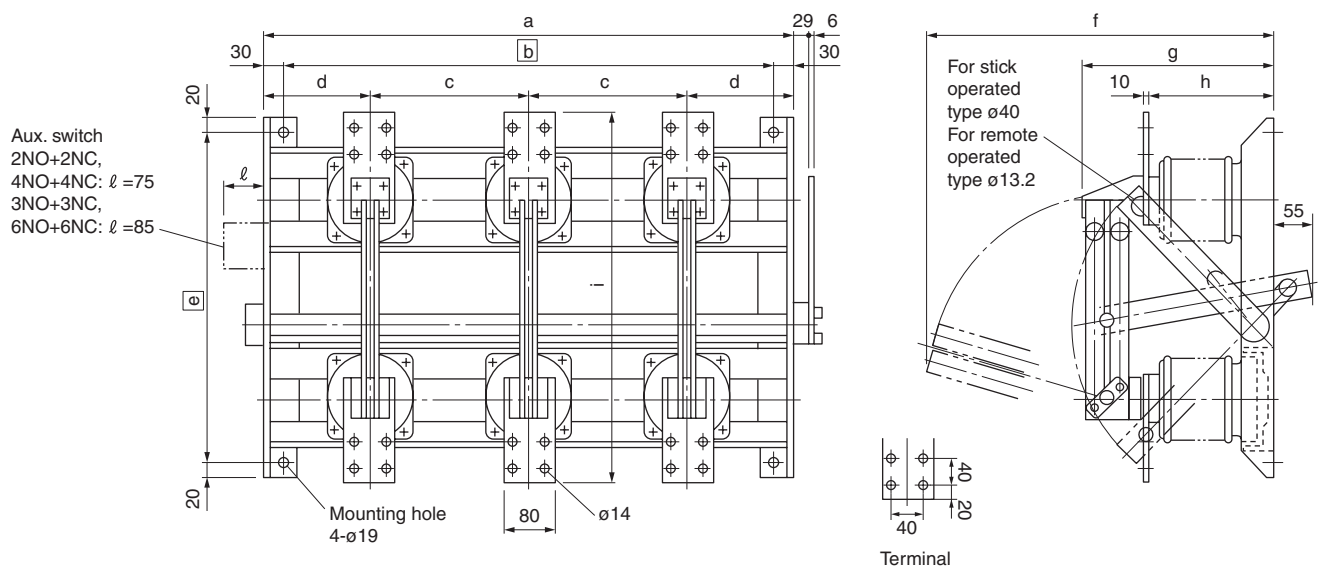

Type	a	b	c	d	e	f	g	h	i
RF240cIII/20/1200	1160	1100	340	240	630	690	376	266	700
RF240cIII/30/1200	1540	1480	440	330	720	868	466	356	780

H.V. Distribution Equipment

Disconnecting switches

RF type

■ Dimensions, mm

RF240cIII/6 – 30/2000 (F-F)

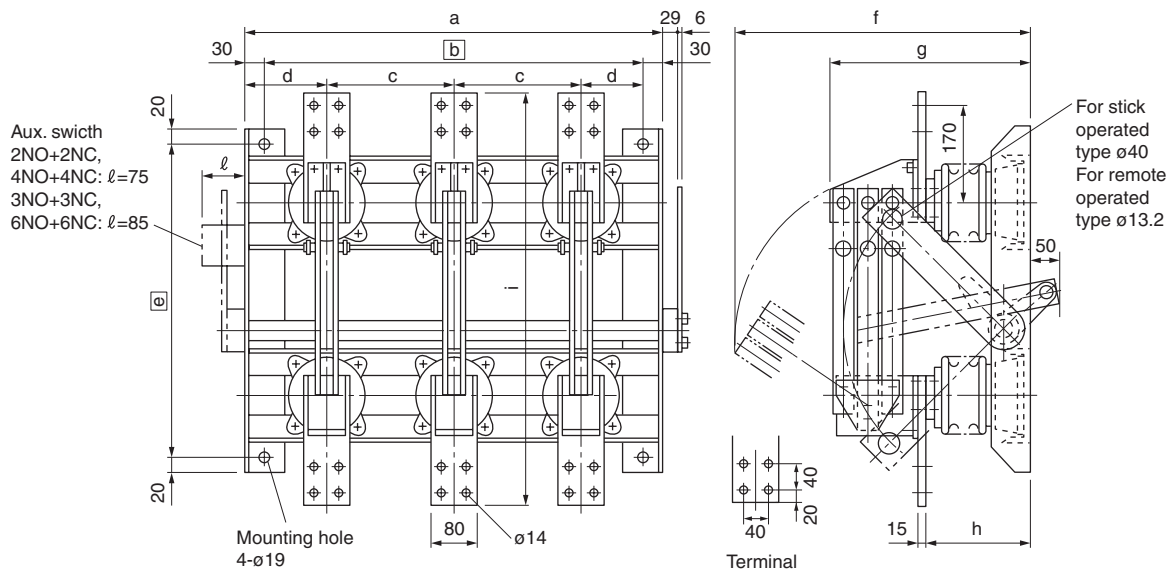

Type	a	b	c	d	e	f	g	h	i
RF240cIII/6/2000	660	600	200	130	490	557	311	161	640
RF240cIII/20/2000	1160	1100	340	240	630	754	416	266	740
RF240cIII/30/2000	1540	1480	440	330	720	935	506	356	820

RF240cIII/6, 20/4000 (F-F)

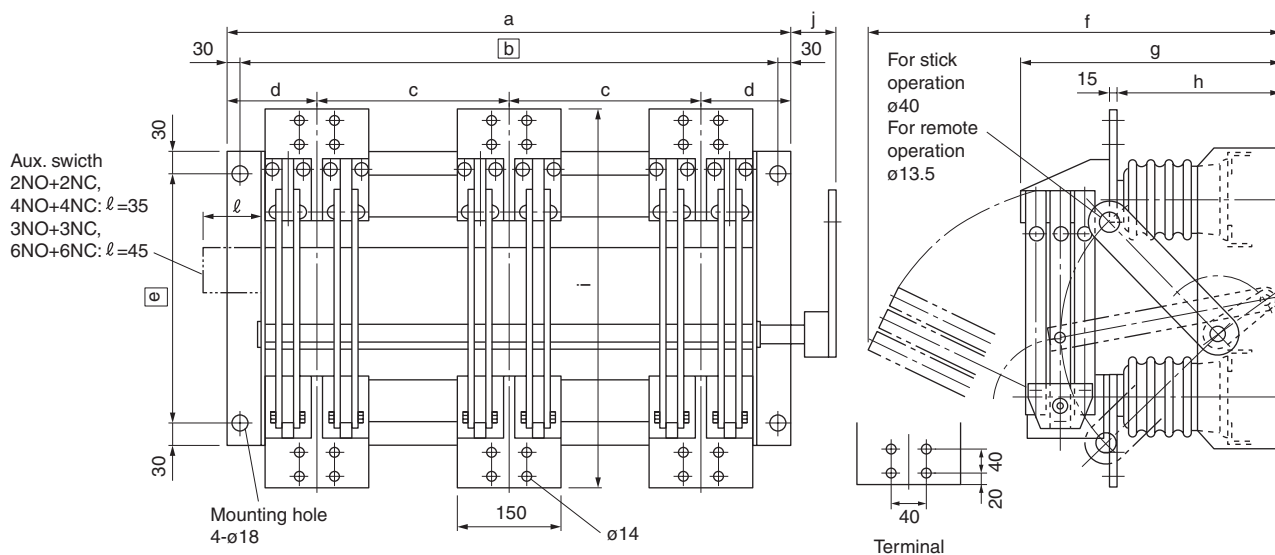

Type	a	b	c	d	e	f	g	h	i	j
RF240cIII/6/4000	920	860	300	160	370	613±10	380	230	620	59
RF240cIII/20/4000	1280	1220	420	220	530	832±10	485	335	740	109

Gang-operated mechanisms for disconnecting switches

■ Description

The V, RF type 3-pole disconnecting switches and the LB type air load break switches can be provided with remote gang-operated mechanisms. The R290-B mechanism is a manual type and is handle-operated. The R293B type is motor driven. An interlocking system prevents incorrect operation. Versions are also available in which locking action is carried out by energizing or de-energizing a solenoid-coil.

■ Features

Motor-driven operating mechanism

- The R293B motor-driven type is provided with an interlocking switch which prevents the motor from being remotely operated when the crank handle is in position.
- AC and DC common-use motors are available in 110 and 220 Volts ratings.
- The R293X motorized control devices are easy to install and improve the integrity of the electrical system. R293X devices are sold separately.
- These mechanisms are provided with manual crank handle so that the disconnecting switch can be operated even if the drive motor is faulty or an electrical interruption has taken place.
- Units are fitted with SPDT contacts for crank handle operation interlock use — when a switch is being operated manually the drive motor cannot be engaged.

Manual operating mechanism

- The R290-B is a new type manual operating mechanism. The switchgear can be fitted to either side.
- The crank lever can be attached at any angle through 360°, and this can be easily repositioned for operating convenience. A tie-rod links it to the disconnecting switch.
- An interlock solenoid coil is provided. An automatic locking mechanism prevents faulty operation.
- If required a 1NC switch for crank handle operating interlock use can be provided.

Please ask FUJI for the installation, dimensions and piping/wiring diagrams.

■ Ordering information

Specify the following:

1. Type number

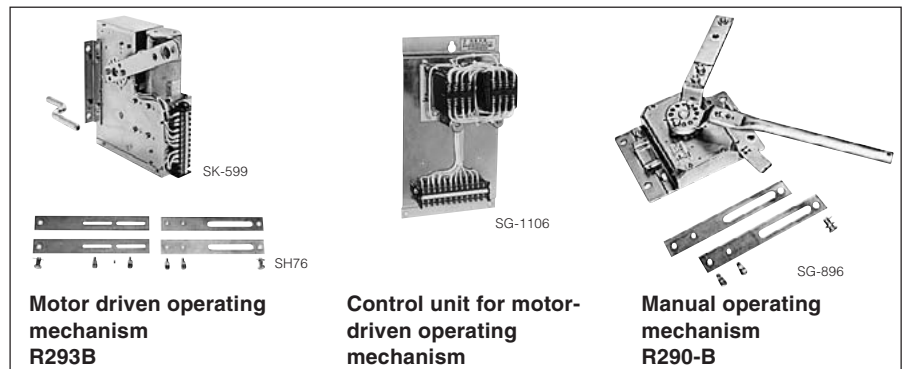

• Motor-driven operating mechanism

Type	Ordering code	Motor ratings	Application
R293B-1	HZ1LT-1	100/110V AC, DC 8.8A	<ul style="list-style-type: none"> • V-type, RF240-type Rated current 1200A or less • Rated current 2000A
R293B-2	HZ1LT-2	200/220V AC, DC 4.4A	
R293BH-1	100/110V AC, DC 8.8A		
R293BH-2	200/220V AC, DC 4.4A		

• Control unit for motor-driven operating mechanism

Type	Ordering code	Motor ratings	Application
R293X-1	HZ1LQ-1	100/110V AC	R293B-1, R293BH-1 type
R293X-2	HZ1LQ-2	200/220V AC	R293B-2, R293BH-2 type
R293X-3	HZ1LQ-3	100/110V DC	R293B-1, R293BH-1 type

• Manual operating mechanism

Type	Ordering code	Interlock coil Unlock-coil energized	Lock-coil energized	Contact for crank handle
R290-B	HZ1VG	—	—	—
R290-BDS	HZ1VH	100/110V DC, 0.1A	—	1NC (110V DC, 1.3A)
R290-BAS	HZ1V1	100/110V AC, 0.1A	—	1NC (110V DC, 1.3A)
R290Z-BAS	HZ1VJ	—	100/110V AC, 0.1A	1NC (110V DC, 1.3A)

Note : 24V DC, 48V DC, 200/220V AC are also available.

• Switch stick

Type	Ordering code	Description	Illustration
HI-10	HZ1VA	<ul style="list-style-type: none"> • Applicable voltage: Less than 12kV Full length: 1m 	
HI-30		<ul style="list-style-type: none"> • Applicable voltage: Less than 36kV Full length: 2m 	

■ Type number nomenclature

• Manual operating mechanism

R290-B D S

- Contact for crank handle**
Blank: Without contact
S: With contact
- Interlock coil**
Blank: Without interlock coil
A: AC coil
D: DC coil
- With pin for lock**
Basic type
R290: Unlock-coil energized
R290Z: Lock-coil energized

• Motor driven operating mechanism

R293B-2

- Operating voltage**
1: 100/110V AC, DC
2: 200/220V AC, DC
- Basic type**

• Control equipment

R293X-2

- Operating voltage**
1: 100/110V AC
2: 200/220V AC
3: 100/110V DC
- Basic type**

H.V. Distribution Equipment

Power fuses

General information

■ Description

FUJI current limiting power fuses are available in general purpose and back-up versions. Type SCF and HF ... E general purpose fuses will interrupt all excessive current ranging from the minimum melting current to the rated interrupting current. They will accurately interrupt a 200 – 300% overcurrent of the rated current. The fuse can be used independently or incorporated with air load break switches not provided with trip mechanisms. Very economical to install. The back-up fuses are rated at 12kV or higher and used with switches provided with trip mechanisms incorporated with CT or OCR.

■ Design features

- These fuses comply with the requirements of JEC-2330. The FUJI power fuses fully meet the requirements of the JIS and JEC Standards, which makes them suitable for a wider range of applications.
- Excellent repeat accuracies
FUJI current limiting power fuses have excellent repeat characteristics from the starting current and meet all the requirements of the Standards. This result from the employment of FUJI's specially developed fusible element which maintains its integrity from deterioration for the extent of its long service life.
- Easy selection
The electrical characteristics of the individual transformer, capacitor or motor can easily be matched with the appropriate type from the wide variety of fuses available.
- Outstanding current limiting characteristics
Since the available short-circuit

current is interrupted within half a cycle the thermal and mechanical strength of the equipment can be greatly reduced.

- Small arc peak voltage
The arc peak voltage at the time of interruption is less than twice the rated voltage. This eliminates the possibility of damage to the insulation of the motor winding and other electrical equipment.
- Wide range interruption
The general purpose power fuses SCF and HF ... E types are capable of interrupting small current overloads in the range of 200% – 300% of their rated current, yet will blow quickly in the face of massive destructive currents. Since they operate without fail through the range of their interrupting capacity they can be used independently and so save construction costs.

■ Construction

- Fuse link
The fusible element consists of a pure silver wire packed in high-purity silica sand in a heat-resisting mechanically strong ceramic barrel.
- Fuse holder
The holder for indoor use uses epoxy resin for insulation and is simple in design. The fuse is easy to replace. The 3-pole holder is provided with the barriers between the poles and the switch is safely operated by stick.
- Blown fuse indicator (indoor use only, except SCF-6/5)
A spring fuse-blown indicator is provided in the fuse ferrule. The indicator is ejected when the fuse is blown. If required the indicator can be fitted with a sensitive switch so that the blown fuse can be identified from a distance.

3-pole fuse holder SCHIII with fuse links

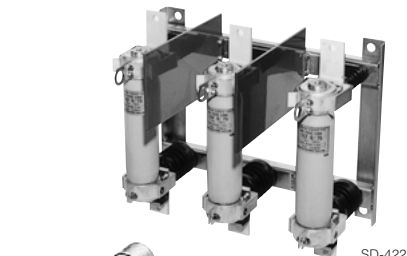

SD-422



SD-423

Fuse link SCF type



SD-430

Single-pole fuse holder SCHA-6 with fuse link



SD-425

Fuse link HF type

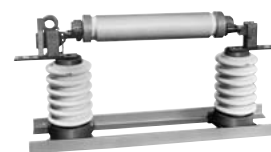

300498

Single-pole fuse holder HF323 with fuse link



SB1068

Fuse links 36kV HFA

■ Melting time-current characteristics and repeat overcurrent characteristics (JIS C 4604 and JEC-2330)

Fuse*1 type	Melting time-current characteristics				Repeat overcurrent characteristics
	Non-melting current	$I_{17,200}/I_n$	I_{110}/I_n	$I_{10.1}/I_n$	
T	When a fuse is subjected to a current 1.3 times its rated current the fusible element will not melt within two hours.	—	$2.5 \leq I_{110}/I_n \leq 10$	$12 \leq I_{10.1}/I_n \leq 25$	The fusible element will not melt when subjected to a current 10 times its rated current for a period of 0.1 seconds one hundred times.
M		—	$6 \leq I_{110}/I_n \leq 10$	$15 \leq I_{10.1}/I_n \leq 35$	The fusible element will not melt when subjected to a current 5 times its rated current for a period of 10 seconds one thousand times.
G		$I_{17,200}/I_n \leq 2$	$2 \leq I_{110}/I_n \leq 5$	$7 \left(\frac{I_n}{100} \right)^{0.25} \leq I_{10.1}/I_n$ $\leq 20 \left(\frac{I_n}{100} \right)^{0.25}$	
C	When a fuse is subjected to a current 2. times its rated current the fusible element will not melt within two hours.	—	$\ast I_{160}/I_n \leq 10$	—	The fusible element will not melt when subjected to a current 70 times its rated current for a period of 0.002 seconds one thousand times.

Note: *1 T: Transformer protection
M: Motor protection
G: General purpose line protection
C: Capacitor protection

I_n : Fuse rated current
 I_{110} : Current (Amps) where melt in 10 sec.
 $I_{10.1}$: Current (Amps) where melt in 0.1 sec.

$I_{17,200}$: Current (Amps) where melt in 2 hours.
 I_{160} : Current (Amps) where melt in 60 sec.

General purpose fuses and back-up fuses

The FUJI current-limiting power fuses are available as either general purpose-types or back-up-types.

General purpose fuses are provided with a wide range of interrupting performance. They can, for instance, interrupt excessive currents in the 200 – 300% range up to massive short-circuit currents. This indicates that they can interrupt currents including the fuse elements's melting current. Since they are the most reliable type of fuse they can be attached to the FUJI LBS, LB-type air load break switches.

They can also be applied independently to H.V. circuits to give them adequate overload protection.

Back-up fuses are used in coordination with the circuit breaker with trip device, OCR and CT. The OCR operates in the face of small overcurrent approx. 200% of the rated current, while the fuse rapidly interrupts in the face of destructive short-circuit current. Although the power fuse has an excellent performance against massive overcurrent yet it has a tendency to explode against the small overcurrent. There is a region where fusible element melts but interruption may not take place. In this case the circuit breaker is required to cover this region.

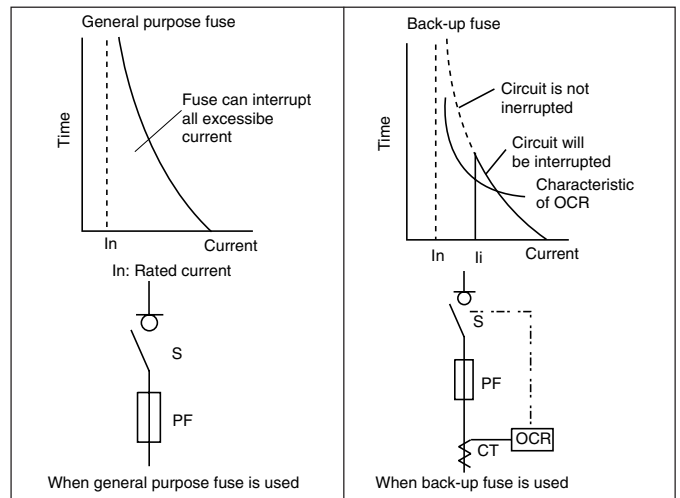

■ Type number of fuse

- General purpose fuses

Nominal current (A)	3.6kV interrupting capacity (kA) *1	Type	7.2kV interrupting capacity (kA) *1	Type	7.2kV interrupting capacity (kA) *1	Type
5	40 (250)	HF337E/3/5	40 (500)	SCF-6/5	40 (500)	HF337E/6/5
10	40 (250)	HF337E/3/10	40 (500)	SCF-6/10	40 (500)	HF337E/6/10
20	40 (250)	HF338E/3/20	40 (500)	SCF-6/20	40 (500)	HF338E/6/20
30	40 (250)	HF338E/3/30	40 (500)	SCF-6/30	40 (500)	HF338E/6/30
40	40 (250)	HF338E/3/40	40 (500)	SCF-6/40	40 (500)	HF338E/6/40
50	40 (250)	HF338E/3/50	20 (250)	SCF-6/50	40 (500)	HF338E/6/50
75	40 (250)	HF338E/3/75	20 (250)	SCF-6/75	40 (500)	HF338E/6/75
100	40 (250)	HF338E/3/100	—	—	40 (500)	HF338E/6/100
150	40 (250)	HF338E/3/150	—	—	40 (500)	HF338E/6/150
200	40 (250)	HF338E/3/200	—	—	31.5 (390)	HF338E/6/200 *2
400	40 (250)	HF338E/3/400 *2	—	—	31.5 (390)	HF338E/6/400 *2

Notes: *1 () indicate MVA. *2 Back-up fuse

- Back-up fuses

Nominal current (A)	12kV interrupting capacity (kA) *1	Type	24kV interrupting capacity (kA) *1	Type	36kV interrupting capacity (kA) *1	Type
5	40 (830)	JR-10/5	40 (1700)	JR-20/5	25 (1600)	JR-30/5
10	40 (830)	HF337/10/10	25 (1000)	HF337/20/10	16 (1000)	HF337/30/10
16	—	—	—	—	32 (2000)	HFB-30/16
20	40 (830)	HF338B/10/20	25 (1000)	HF338B/20/20	—	—
25	—	—	—	—	32 (2000)	HFB-30/25
30	40 (830)	HF338B/10/30	25 (1000)	HF338B/20/30	—	—
40	40 (830)	HF338B/10/40	25 (1000)	HF338B/20/40	32 (2000)	HFB-30/40
50	40 (830)	HF338B/10/50	—	—	—	—
75	40 (830)	HF338B/10/75	—	—	—	—
80	—	—	25 (1000)	2xHF338B/20/40	32 (2000)	2xHFB-30/40
100	40 (830)	HF338B/10/100	—	—	—	—
150	40 (830)	2xHF338B/10/75	—	—	—	—
200	40 (830)	2xHF338B/10/100	—	—	—	—

Note: *1 () indicate MVA.

■ Repeat operating life of general purpose fuses

Transformer circuit Rated voltage (kV)	Type	Transformer rated current (A)	Repeat operations	Motor circuit Rated voltage (kV)	Type	Motor rated current (A)	Repeat operations
3.6	HF338E/3/100	75	10000 operations	3.6	HF338E/3/50	20	15000 operations
	HF338E/3/150	100			HF338E/3/200	100	
7.2	SCF-6/30	15	10000 operations		HF338E/3/400	200	
	HF338E/6/30	15		7.2	SCF-6/75	30	
	SCF-6/75	60			HF338E/6/75	30	
	HF338E/6/75	60			HF338E/6/200	100	
	HF338E/6/150	100			HF338E/6/400	200	
	HF338E/6/400	300					

Note: Refer to repeat overcurrent characteristics on [page 11/10](#).

H.V. Distribution Equipment

Power fuses

Applications

■ Quick selection guide

• 3.3kV oil immersed type transformers

3-phase transformers			Single-phase transformers		
Capacity (kVA)	Rated current (A)	Recommended FUJI fuse Type	Capacity (kVA)	Rated current (A)	Recommended FUJI fuse Type
5	0.88	HF337E/3/5	5	1.52	HF337E/3/5
7.5	1.31	HF337E/3/5	7.5	2.28	HF337E/3/10
10	1.75	HF337E/3/5	10	3.03	HF337E/3/10
15	2.63	HF337E/3/10	15	4.55	HF338E/3/20
20	3.5	HF337E/3/10	20	6.05	HF338E/3/20
25	4.36	HF338E/3/20	25	7.6	HF338E/3/20
30	5.25	HF338E/3/20	30	9.1	HF338E/3/20
50	8.75	HF338E/3/20	50	15.2	HF338E/3/30
75	13.1	HF338E/3/30	75	22.8	HF338E/3/50
100	17.5	HF338E/3/30	100	30.3	HF338E/3/75
150	26.3	HF338E/3/40	150	45.5	HF338E/3/100
200	35	HF338E/3/50	200	60.5	HF338E/3/100
250	43.6	HF338E/3/75	250	76	HF338E/3/100
300	52.5	HF338E/3/75	300	91	HF338E/3/150
500	87.5	HF338E/3/150	500	152	HF338E/3/200
750	131	HF338E/3/200	750	227	HF338E/3/400
1000	175	HF338E/3/400	1000	303	HF338E/3/400

Note: Selection based on FUJI standard transformer.

• 6.6kV oil immersed type transformers

3-phase transformers				Single-phase transformers			
Capacity (kVA)	Rated current (A)	Recommended FUJI fuse SCF series Type	HF series Type	Capacity (kVA)	Rated current (A)	Recommended FUJI fuse SCF series Type	HF series Type
5	0.44	SCF-6/5	HF337E/6/5	5	0.76	SCF-6/5	HF337E/6/5
7.5	0.66	SCF-6/5	HF337E/6/5	7.5	1.14	SCF-6/5	HF337E/6/5
10	0.88	SCF-6/5	HF337E/6/5	10	1.51	SCF-6/10	HF337E/6/10
15	1.31	SCF-6/5	HF337E/6/5	15	2.28	SCF-6/10	HF337E/6/10
20	1.75	SCF-6/10	HF337E/6/10	20	3.0	SCF-6/10	HF337E/6/10
25	2.19	SCF-6/10	HF337E/6/10	25	3.8	SCF-6/20	HF338E/6/20
30	2.63	SCF-6/10	HF337E/6/10	30	4.5	SCF-6/20	HF338E/6/20
50	4.36	SCF-6/20	HF338E/6/20	50	7.6	SCF-6/20	HF338E/6/20
75	6.55	SCF-6/20	HF338E/6/20	75	11.4	SCF-6/40	HF338E/6/40
100	8.75	SCF-6/30	HF338E/6/30	100	15.2	SCF-6/50	HF338E/6/50
150	13.1	SCF-6/30	HF338E/6/30	150	22.8	SCF-6/50	HF338E/6/50
200	17.5	SCF-6/40	HF338E/6/40	200	30.3	SCF-6/75	HF338E/6/75
250	21.9	SCF-6/40	HF338E/6/40	250	38	SCF-6/75	HF338E/6/75
300	26.3	SCF-6/50	HF338E/6/50	300	45	SCF-6/75	HF338E/6/75
500	43.6	SCF-6/75	HF338E/6/75	500	76	—	HF338E/6/100
750	65.5	—	HF338E/6/100	750	114	—	HF338E/6/200
1000	87.5	—	HF338E/6/150	1000	152	—	HF338E/6/200

Note: Selection based on FUJI standard transformer.

• 11kV oil immersed type transformers

3-phase transformers			Single-phase transformers		
Capacity (kVA)	Rated current (A)	Recommended FUJI fuse Type	Capacity (kVA)	Rated current (A)	Recommended FUJI fuse Type
15	0.79	JR-10/5	15	1.36	HF337/10/10
20	1.05	JR-10/5	20	1.82	HF337/10/10
25	1.31	HF337/10/10	25	2.27	HF337/10/10
30	1.57	HF337/10/10	30	2.73	HF338B/10/20
50	2.62	HF337/10/10	50	4.55	HF338B/10/20
75	3.94	HF338B/10/20	75	6.82	HF338B/10/20
100	5.25	HF338B/10/20	100	9.09	HF338B/10/30
150	7.87	HF338B/10/30	150	13.6	HF338B/10/40
200	10.5	HF338B/10/30	200	18.2	HF338B/10/40
250	13.1	HF338B/10/40	250	22.7	HF338B/10/50
300	15.8	HF338B/10/40	300	27.3	HF338B/10/75
500	26.2	HF338B/10/50	500	45.5	HF338B/10/75
750	39.4	HF338B/10/75	750	68.2	HF338B/10/100
1000	52.5	HF338B/10/100	1000	90.9	2xHF338B/10/100

Note: Selection based on 10Xrated current –0.1 sec. transformer inrush current.

■ Quick selection guide

• 22kV oil immersed type transformers

3-phase transformers			Single-phase transformers		
Capacity (kVA)	Rated current (A)	Recommended FUJI fuse Type	Capacity (kVA)	Rated current (A)	Recommended FUJI fuse Type
15	0.39	JR-20/5	15	0.68	JR-20/5
20	0.52	JR-20/5	20	0.91	JR-20/5
25	0.66	JR-20/5	25	1.14	JR-20/5
30	0.79	JR-20/5			
50	1.31	HF337/20/10	30	1.36	HF337/20/10
75	1.97	HF337/20/10	50	2.27	HF337/20/10
100	2.62	HF337/20/10	75	3.41	HF338B/20/20
			100	4.55	HF338B/20/20
			150	6.82	HF338B/20/20
150	3.94	HF338B/20/20			
200	5.25	HF338B/20/20	200	9.1	HF338B/20/30
250	6.56	HF338B/20/20	250	11.4	HF338B/20/30
300	7.87	HF338B/20/30	300	13.6	HF338B/20/40
500	13.1	HF338B/20/40	500	22.7	2xHF338B/20/40
750	19.7	HF338B/20/40	750	34.1	2xHF338B/20/40
1000	29.2	2xHF338B/20/40			

Note: Selection based on 10Xrated current –0.1 sec. transformer inrush current.

• 33kV oil immersed type transformers

3-phase transformers			Single-phase transformers		
Capacity (kVA)	Rated current (A)	Recommended FUJI fuse Type	Capacity (kVA)	Rated current (A)	Recommended FUJI fuse Type
15	0.26	JR-30/5	15	0.45	JR-30/5
20	0.35	JR-30/5	20	0.61	JR-30/5
25	0.44	JR-30/5			
30	0.52	JR-30/5	25	0.76	JR-30/5
50	0.87	JR-30/5	30	0.91	JR-30/5
			50	1.52	HF337/30/10
75	1.31	HF337/30/10			
100	1.75	HF337/30/10	75	2.27	HF337/30/10
150	2.62	HF337/30/10	100	3.03	HFB-30/16
200	3.5	HFB-30/16	150	4.55	HFB-30/16
250	4.37	HFB-30/16	200	6.06	HFB-30/25
300	5.25	HFB-30/25	250	7.6	HFB-30/25
500	8.75	HFB-30/40	300	9.1	HFB-30/40
750	13.1	2xHFB-30/40	500	15.1	2xHFB-30/40
1000	17.5	2xHFB-30/40	750	22.2	2xHFB-30/40

Note: Selection based on 10Xrated current –0.1 sec. transformer inrush current.

• 3.3/6.6kV FM-KF type cast-resin transformers

3.3kV			6.6kV		
Capacity (kVA)	3-phase Recommended FUJI fuse Type	Single-phase Recommended FUJI fuse Type	Capacity (kVA)	3-phase Recommended FUJI fuse Type	Single-phase Recommended FUJI fuse Type
10	HF338E/3/20	HF338E/3/20	10	SCF-6/20	SCF-6/10
20	HF338E/3/20	HF338E/3/20		HF337E/6/20	HF337E/6/10
30	HF338E/3/20	HF338E/3/30	20	SCF-6/20	SCF-6/20
				HF338E/6/20	HF338E/6/20
50	HF338E/3/30	HF338E/3/40			
75	HF338E/3/40	HF338E/3/50	30	SCF-6/20	SCF-6/20
100	HF338E/3/40	HF338E/3/75		HF338E/6/20	HF338E/6/20
			50	SCF-6/20	SCF-6/30
150	HF338E/3/50	HF338E/3/100		HF338E/6/20	HF338E/6/30
200	HF338E/3/75	HF338E/3/100			
300	HF338E/3/100	HF338E/3/200	75	SCF-6/20	SCF-6/30
				HF338E/6/20	HF338E/6/30
500	HF338E/3/150		100	SCF-6/30	SCF-6/40
				HF338E/6/30	HF338E/6/40
			150	SCF-6/40	SCF-6/50
				HF338E/6/40	HF338E/6/50
			200	SCF-6/40	SCF-6/75
				HF338E/6/40	HF338E/6/75
			300	SCF-6/75	—
				HF338E/6/75	HF338E/6/100
			500	HF338E/6/100	—

Note: Selection based on FUJI standard transformer.

H.V. Distribution Equipment

Power fuses

Applications

■ Quick selection guide

• Single- and 3-phase oil immersed type transformer connection

3.3kV circuits

1 ϕ transformer capacity 3 ϕ transformer capacity	—	5kVA	7.5kVA	10kVA	15kVA	20kVA	30kVA	50kVA	75kVA	100kVA
—	—	HF337E/3/5	HF337E/3/10					HF338E/3/30	HF338E/3/50	
5kVA	HF337E/3/5	HF337E/3/10								
10kVA			HF338E/3/20							
15kVA	HF337E/3/10				HF338E/3/30					
20kVA										
30kVA								HF338E/3/50		
50kVA		HF338E/3/30			HF338E/3/40					HF338E/3/100
75kVA	HF338E/3/30									
100kVA					HF338E/3/50			HF338E/3/75		
150kVA	HF338E/3/40									

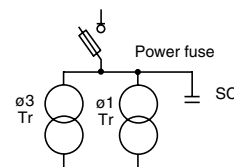

6.6kV circuits

1 ϕ transformer capacity 3 ϕ transformer capacity	—	5kVA	7.5kVA	10kVA	15kVA	20kVA	30kVA	50kVA	75kVA	100kVA
—	—	SCF-6/5 HF337E/6/5								
5kVA										
10kVA	SCF-6/5 HF337E/6/5		SCF-6/10 HF337E/6/10							
15kVA										
20kVA										
30kVA				SCF-6/20 HF338E/6/20						
50kVA										
75kVA										
100kVA				SCF-6/30 HF338E/6/30						
150kVA										
200kVA					SCF-6/40 HF338E/6/40					SCF-6/75 HF338E/6/75
250kVA										
300kVA						SCF-6/50 HF338E/6/50				
500kVA			SCF-6/75		HF338E/6/75					HF338E/6/100

Notes:

1. Select the rated current of power fuse .
2. These tables are based on the fact that capacity of capacitor (SC) is less than 1/3 of transformer total capacity (kVA) and that the transformer inrush current is 10 × rated current , 0.1 sec.

Primary fuse protection of transformers (Simple selection method)

Series	Maximum current of transformer circuit (A)	Fuse type
SCF	1.5	SCF-6/5
	3.2	SCF-6/10
	7.4	SCF-6/20
	13	SCF-6/30
	21	SCF-6/40
HH337E	28	SCF-6/50
	46	SCF-6/75
	HH338E	1.5
3.2		HF337E/3/10, HF337E/6/10
8.2		HF338E/3/20, HF338E/6/20
14		HF338E/3/30, HF338E/6/30
22		HF338E/3/40, HF338E/6/40
30	HF338E/3/50, HF338E/6/50	
52	HF338E/3/75, HF338E/6/75	
82	HF338E/3/100, HF338E/6/100	

1. Selection of the primary fuse, exciting current (r.m.s.) will be determined on the basis of a current 10 times the rated full-load current for the transformer which will flow for 0.1 sec.

2. When a group of three or single-phase transformers is connected in parallel, calculate the I_R , I_S and I_T maximum load line currents of the transformers to determine the largest, and select fuses by use of the table.

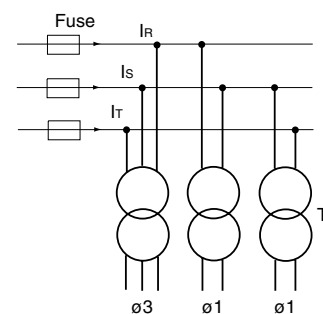

■ Quick selection guide
 • 3.3kV induction motors

Motor capacity (kW)	Squirrel-cage type			Fuse type		Wound-rotor type			Fuse type	
	Rated current (A)	Rush current (A)	Starting time (Sec.)	Normal operating	Twice repeat operating	Rated current (A)	Rush current (A)	Starting time (Sec.)	Normal operating	Twice repeat operating
37	11	73	5	HF338E/3/40	HF338E/3/50	10.7	16.1	17	HF338E/3/20	HF338E/3/20
55	15.5	100	5	HF338E/3/75	HF338E/3/75	15.1	22.5	19	HF338E/3/20	HF338E/3/20
75	20.6	135	5	HF338E/3/75	HF338E/3/75	20.1	30.2	22	HF338E/3/30	HF338E/3/30
90	24	157.9	5	HF338E/3/75	HF338E/3/100	23.4	34.9	23	HF338E/3/30	HF338E/3/30
110	29.1	185	5	HF338E/3/100	HF338E/3/100	28.4	42.5	25	HF338E/3/40	HF338E/3/40
132	34.3	215	5	HF338E/3/100	HF338E/3/150	33.5	50.1	27	HF338E/3/40	HF338E/3/40
160	41.1	260.2	5	HF338E/3/150	HF338E/3/150	40.2	60.1	30	HF338E/3/50	HF338E/3/50
200	51.1	320	5	HF338E/3/150	HF338E/3/200	49.8	74.5	33	HF338E/3/75	HF338E/3/75
250	59.5	330	10	HF338E/3/200	HF338E/3/200	58	86.8	36	HF338E/3/75	HF338E/3/75
280	68	377.2	10	HF338E/3/200	HF338E/3/200	66.3	99.2	38	HF338E/3/100	HF338E/3/100
315	78.1	407	10	HF338E/3/200	HF338E/3/200	77.6	116.1	40	HF338E/3/100	HF338E/3/100
355	86.2	474.1	10	HF338E/3/200	HF338E/3/400	84.4	126.3	42	HF338E/3/100	HF338E/3/100
400	102	563	10	HF338E/3/400	HF338E/3/400	100.2	149.9	44	HF338E/3/150	HF338E/3/150
450	114.3	629	10	HF338E/3/400	HF338E/3/400	112.3	168	47	HF338E/3/150	HF338E/3/150
500	128.7	703	10	HF338E/3/400	HF338E/3/400	128.7	192.6	49	HF338E/3/200	HF338E/3/200
560	144.1	798	15	HF338E/3/400	HF338E/3/400	144.1	215.6	52	HF338E/3/200	HF338E/3/200
630	162.6	898	15	HF338E/3/400	—	162.6	243.3	55	HF338E/3/200	HF338E/3/200

- Note: 1. Full load current and starting current values: Motors with ratings of 200kW or less meet the requirements of JEM 1381. Motors with ratings of over 250kW conform to the requirements of FUJI standard motors.
 2. Fuse rated values are selected on the basis of G-type fuses. (Please refer to Page 11/10).

• 6.6kV induction motors

Motor capacity (kW)	Rated current (A)	Squirrel-cage type		Wound-rotor type	
		Fuse type Normal operating	Twice repeat operating	Fuse type Normal operating	Twice repeat operating
250	29	HF338E/6/100	HF338E/6/150	SCF-6/40 HF338E/6/40	SCF-6/40 HF338E/6/40
315	38	HF338E/6/150	HF338E/6/150	SCF-6/40 HF338E/6/40	SCF-6/50 HF338E/6/50
375	45	HF338E/6/150	HF338E/6/200	SCF-6/50 HF338E/6/50	SCF-6/75 HF338E/6/75
450	54	HF338E/6/200	HF338E/6/200	SCF-6/75 HF338E/6/75	SCF-6/75 HF338E/6/75
530	63	HF338E/6/200	HF338E/6/400	SCF-6/75 HF338E/6/75	SCF-6/75 HF338E/6/75
630	74	HF338E/6/400	HF338E/6/400	HF338E/6/100	HF338E/6/100
750	89	HF338E/6/400	HF338E/6/400	HF338E/6/100	HF338E/6/100
850	100	HF338E/6/400	HF338E/6/400	HF338E/6/150	HF338E/6/150
950	110	HF338E/6/400	HF338E/6/400	HF338E/6/150	HF338E/6/150
1050	121	HF338E/6/400	—	HF338E/6/150	HF338E/6/150
1200	138	—	—	HF338E/6/200	HF338E/6/200
1320	152	—	—	HF338E/6/200	HF338E/6/200
1500	172	—	—	HF338E/6/200	HF338E/6/200

- Note: 1. The application recommendations are based on the ratings for FUJI standard 4-pole motors.
 2. The starting current and the starting time differ according to the load GD². However, the type of fuse has been selected on the basis of the most typical value. When special operations are involved please contact FUJI.
 3. Fuse rated values are selected on the basis of G-type fuses. (Please refer to Page 11/10).
 4. When 2-step starting is required please consider the starting time for selecting the fuse:
 The starting time (i.e., the time before the rated speed is reached) is twice the time taken for 1-step starting.

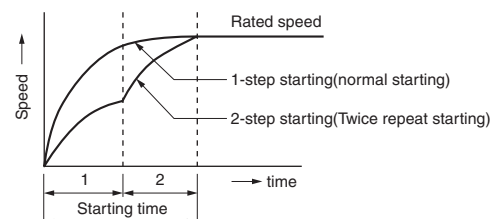

H.V. Distribution Equipment

Power fuses

Applications

■ Quick selection guide

• 3.3/6.6kV capacitor

Capacity (kVA)	3-phase 3.3kV Rated current (A)	Fuse type	3-phase 6.6kV Rated current (A)	Fuse type
5	0.88	HF337E/3/10	0.44	SCF-6/5 HF337E/6/5
7.5	1.31	HF337E/3/10	0.66	SCF-6/5 HF337E/6/5
10	1.75	HF337E/3/10	0.88	SCF-6/10 HF337E/6/10
15	2.62	HF338E/3/20	1.31	SCF-6/10 HF337E/6/10
20	3.5	HF338E/3/20	1.75	SCF-6/10 HF337E/6/10
25	4.37	HF338E/3/20	2.2	SCF-6/10 HF337E/6/10
30	5.25	HF338E/3/20	2.62	SCF-6/20 HF338E/6/20
50	8.8	HF338E/3/30	4.37	SCF-6/20 HF338E/6/20
75	13.1	HF338E/3/30	6.56	SCF-6/20 HF338E/6/20
100	17.5	HF338E/3/40	8.75	SCF-6/30 HF338E/6/30
150	26.2	HF338E/3/50	13.1	SCF-6/30 HF338E/6/30
200	35	HF338E/3/75	17.5	SCF-6/40 HF338E/6/40
250	43.7	HF338E/3/75	21.9	SCF-6/50 HF338E/6/50
300	52.4	HF338E/3/100	26.2	SCF-6/50 HF338E/6/50
400	70	HF338E/3/100	35	SCF-6/75 HF338E/6/75
500	87.4	HF338E/3/150	43.7	SCF-6/75 HF338E/6/75

Note: 1. Selection based on the capacitor inrush current of 70 times rated current, 2ms.

2. Fuse rated values are selected on the basis of G-type fuses.
(Please refer to Page 11/10).

• 11/22/33kV capacitor



Capacity (kVA)	3-phase 11kV Rated current (A)	Fuse type	3-phase 22kV Rated current (A)	Fuse type	3-phase 33kV Rated current (A)	Fuse type
15	0.79	JR-10/5	0.39	JR-20/5	0.26	JR-30/5
20	1.05	JR-10/5	0.53	JR-20/5	0.35	JR-30/5
25	1.31	HF337/10/10	0.66	HF337/20/10	0.44	JR-30/5
30	1.56	HF337/10/10	0.79	HF337/20/10	0.53	JR-30/5
50	2.63	HF337/10/10	1.31	HF337/20/10	0.88	JR-30/5
75	3.94	HF338B/10/20	1.97	HF338B/20/20	1.31	HF337/30/10
100	5.25	HF338B/10/20	2.63	HF338B/20/20	1.75	HF337/30/10
150	7.87	HF338B/10/30	3.93	HF338B/20/20	2.63	HF337/30/10
200	10.5	HF338B/10/40	5.25	HF338B/20/20	3.5	HFB-30/16
250	13.1	HF338B/10/40	6.55	HF338B/20/30	4.36	HFB-30/16
300	15.8	HF338B/10/50	7.87	HF338B/20/30	5.25	HFB-30/16
500	26.3	HF338B/10/75	13.1	HF338B/20/40	8.75	HFB-30/25
750	39.4	HF338B/10/100	19.7	2xHF338B/20/40	13.1	HFB-30/40
1000	52.5	2xHF338B/10/75	26.3	—	17.5	2xHFB-30/40

Note: Selection based on the capacitor inrush current, 70 times rated current –2ms.

■ Quick selection guide

General purpose fuses

• Fuse-link

Illustration	Ratings		Current (A)	Type	Ordering code	Mass (kg)	Applicable fuse-holder	
	Voltage (kV)	Interrupting capacity (kA)					Indoor use Type	Outdoor use Type
 SD-423 SCF-6/30 30A	7.2	40 (500MVA)	5	SCF-6/5	HF2S-005	1.3	SCHA-6 SCHIII-6	—
			10	SCF-6/10	HF2S-010	1.3		
			20	SCF-6/20	HF2S-020	1.3		
			30	SCF-6/30	HF2S-030	1.3		
			40	SCF-6/40	HF2S-040	1.3		
			20 (250MVA)	50	SCF-6/50	HF2S-050		
 SD-424 HF337E/3/10 10A HF338E/3/100 100A	3.6	40 (250MVA)	5	HF337E/3/5	HF1A-005	1.0	HF340/6a HF340III/6a	HF326C/6a
			10	HF337E/3/10	HF1A-010	1.0		
			20	HF338E/3/20	HF1E-020	2.5		
			30	HF338E/3/30	HF1E-030	2.5		
			40	HF338E/3/40	HF1E-040	2.5		
			50	HF338E/3/50	HF1E-050	2.5		
			75	HF338E/3/75	HF1E-075	2.5		
			100	HF338E/3/100	HF1E-100	2.5		
			150	HF338E/3/150	HF1E-150	4.0		
			200	HF338E/3/200	HF1E-200	4.0		
			400	HF338E/3/400*	HF1E-400	6.5		
			 SD-425 HF338E/6/400 400A	7.2	40 (500MVA)	5		
10	HF337E/6/10	HF2A-010				1.0		
20	HF338E/6/20	HF2E-020				2.5		
30	HF338E/6/30	HF2E-030				2.5		
40	HF338E/6/40	HF2E-040				3.0		
50	HF338E/6/50	HF2E-050				3.0		
75	HF338E/6/75	HF2E-075				3.0		
100	HF338E/6/100	HF2E-100				3.0		
150	HF338E/6/150	HF2E-150				3.0		
200	HF338E/6/200*	HF2E-200				3.0		
31.5 (390MVA)	400	HF338E/6/400*	HF2E-400	6.5				

Note: * Back up fuse.

• Fuse-holder

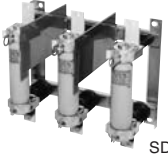
Illustration	Rated voltage (kV)	Usage	Poles	Type	Ordering code	Mass (kg)		
 SD-428 HF	3.6/7.2	Indoor use	1	HF340/6a	HE3E	3.0		
			1	HF340/6b	HE3F	3.5		
			1	HF323/6e	HE3U	16.5*		
			3	HF340III/6a	HE3P	7.0		
			3	HF340III/6b	HE3Q	8.0		
 SD-422 SCHIII-6	3.6/7.2	Outdoor use	1	HF326C/6a	HE3R	21.5*		
			1	HF326C/6b	HE3K	22.0*		
			1	HF326CII/6b	HE3L	24.0*		
	7.2	Indoor use	1	SCHA-6	HE3S	3.3		
			3	SCHIII-6	HE3T	7.0		

Note: Mass does not include fuse-link.
 * With porcelain insulator.

H.V. Distribution Equipment

Power fuses & fuse holders

12, 24, and 36kV

■ Types and ratings

Back-up fuses (Rated minimum breaking current: 3 × Rated current)

• Fuse-link

Illustration	Ratings		Current (A)	Type	Ordering code	Mass (kg)	Applicable fuse-holder					
	Voltage (kV)	Interrupting capacity (kA)					Indoor use Type	Outdoor use Type				
 <p>SB-1068</p> <p>Fuse link 36kV</p>	12	40 (830MVA)	5	JR-10/5	HF4J-005	1.0	JT-10Z HF323/10a	— HF326/10a				
			10	HF337/10/10	HF4Q-010	1.5						
			20	HF338B/10/20	HF4D-020	3.0			HF323/10b	HF326/10b		
			30	HF338B/10/30	HF4D-030	3.0						
			40	HF338B/10/40	HF4D-040	3.0						
			50	HF338B/10/50	HF4D-050	3.0						
			75	HF338B/10/75	HF4D-075	3.0						
			100	HF338B/10/100	HF4D-100	3.0						
			150	2xHF338B/10/75	HF4D-075	6.0			HF323II/10b	HF326II/10b		
			200	2xHF338B/10/100	HF4D-100	6.0						
			24	40 (1700MVA) 25 (1000MVA)	5	JR-20/5			HF6J-005	1.5	JT-20Z HF323/20	— HF326/20
					10	HF337/20/10			HF6Q-010	2.0		
	20	HF338B/20/20			HF6D-020	3.5						
	30	HF338B/20/30			HF6D-030	3.5						
	40	HF338B/20/40			HF6D-040	3.5						
	80	2xHF338B/20/40			HF6D-080	7.0	HF323II/20	HF326II/20				
	36	25 (1600MVA) 16 (1000MVA)	5	JR-30/5	HF8J-005	2.0	JT-30Z HF323/30	— HF326/30				
			10	HF337/30/10	HF8Q-010	2.5						
			16	HFB-30/16	HF8H-016	4.6						
			25	HFB-30/25	HF8H-025	6.8						
			40	HFB-30/40	HF8H-040	6.8						
			80	2xHFB-30/40	HF8H-080	13.6			HF323II/30	HF326II/30		
		32 (2000MVA)	16	HFB-30/16	HF8H-016	4.6						
			25	HFB-30/25	HF8H-025	6.8						
40			HFB-30/40	HF8H-040	6.8							
80			2xHFB-30/40	HF8H-080	13.6							
16			HFB-30/16	HF8H-016	4.6							
25			HFB-30/25	HF8H-025	6.8							

• Fuse-holder

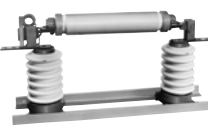
Illustration	Rated voltage (kV)	Usage	Poles	Type	Ordering code	Mass (kg)			
 <p>300498</p> <p>HF323/10</p>	12	Indoor use	1	HF323/10a	HE4E	17			
				HF323/10b	HE4E-S	18			
				HF323II/10b	HE4E-L	20			
		Outdoor use		HF326/10a	HE4R	21			
				HF326/10b	HE4K	23			
				HF326II/10b	HE4L	25			
	24	Indoor use	1	HF323/20	HE6M	23			
				HF323II/20	HE6G	25			
				HF326/20	HE6N	31			
		Outdoor use		HF326II/20	HE6L	33			
				36	Indoor use	1	HF323/30	HE8M	30
							HF323II/30	HE8G	32
HF326/30	HE8N	41							
Outdoor use	HF326II/30	HE8L	43						
	HF326/30	HE8N	41						
	HF326II/30	HE8L	43						

Note: Mass does not include fuse-link.

■ Ordering information

Specify the following:

1. Type number
2. Rated voltage
3. Rated current

When ordering fuse-holder (HF type indoor use) with remote operation indicating device, add "S" to the end of type number.

Example

- Fuse-link
7.2kV HF-type general purpose fuse.
Rated current 100A
Interrupting capacity 40kA
Type number: HF338E/6/100
- Fuse-holder (for above fuse-link)
7.2kV 100A Single-pole Indoor use
Type number: HF340/6b

■ Type number nomenclature

• Fuse-link

SCF - 6/5

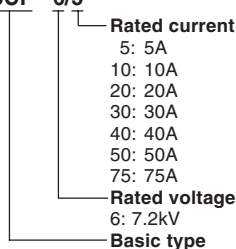

HF337E / 6 / 10

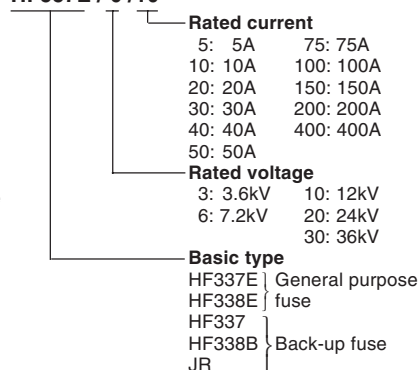

• Fuse-holder

SCHA - 6

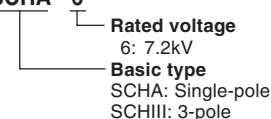

HF340 III / 6

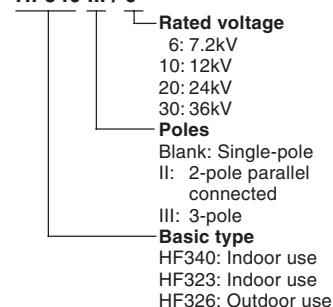

■ Characteristic curves
 • General purpose fuses

Current-limiting characteristic curves
 SCF-type 7.2kV

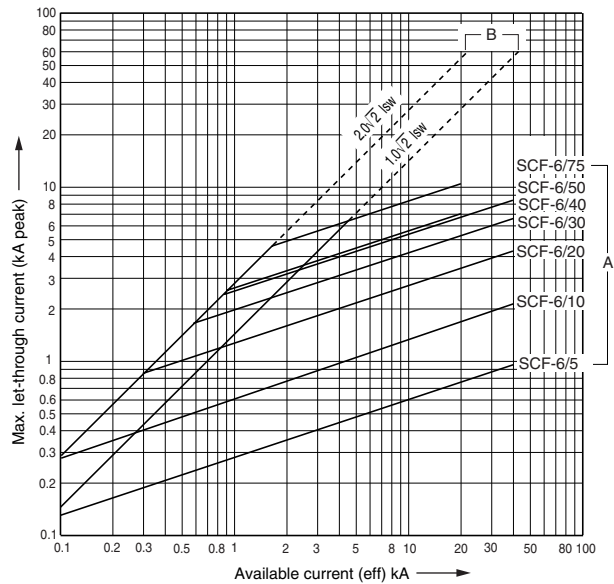

HF-type 3.6 / 7.2kV (E type)

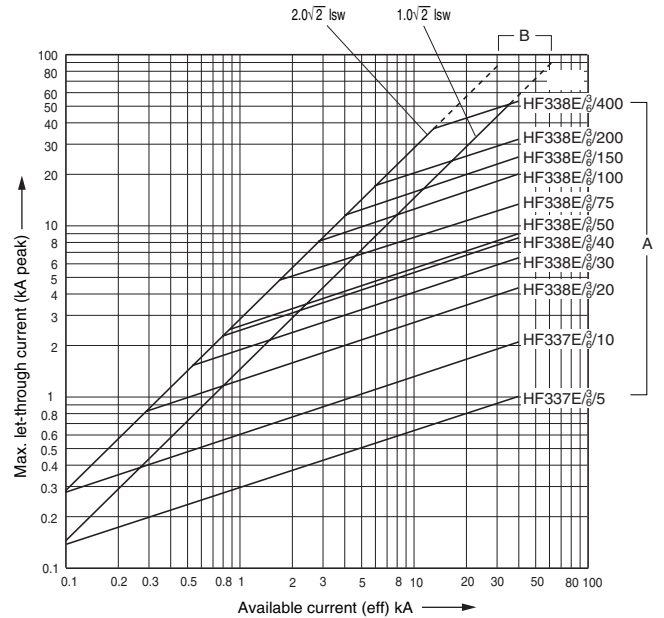

Permissible time-current characteristic curves
 SCF-type 7.2kV

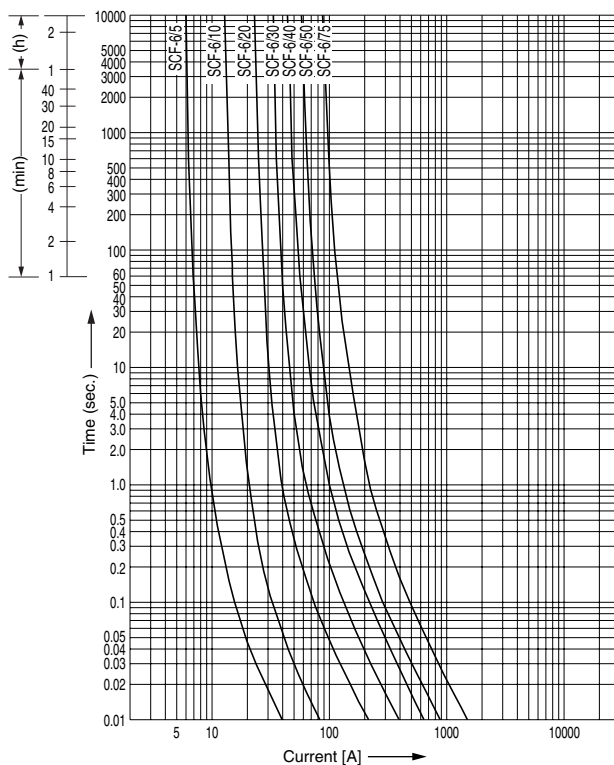

HF-type 3.6 / 7.2kV (E type)

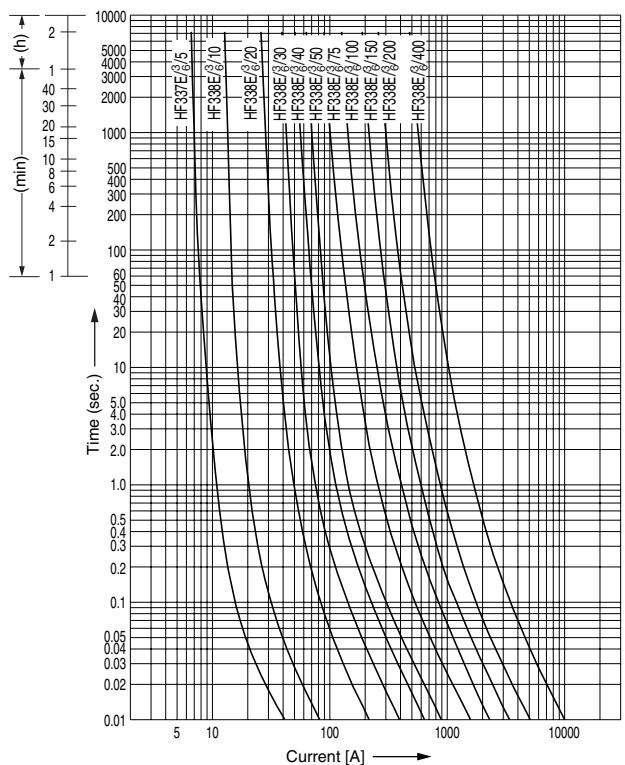

H.V. Distribution Equipment

Power fuses

3.6 and 7.2kV

- General purpose fuses

Melting time-current characteristic curves (Pre-arcing)

SCF-type 7.2kV

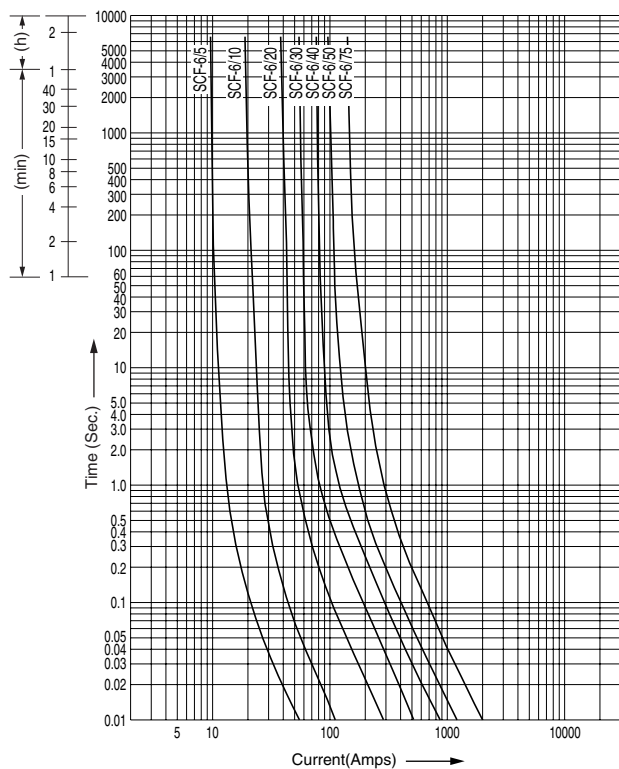

HF-type 3.6 / 7.2kV (E type)

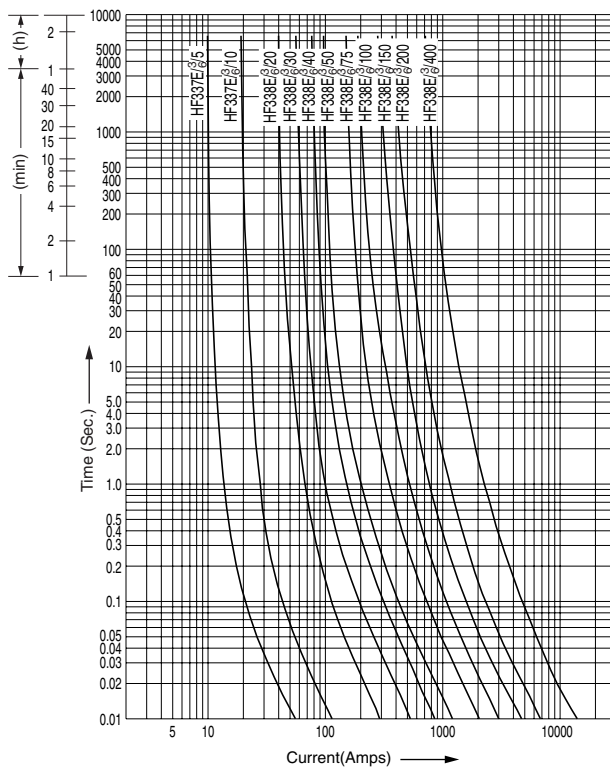

Total clearing (operating) time-current characteristic curves

SCF-type 7.2kV

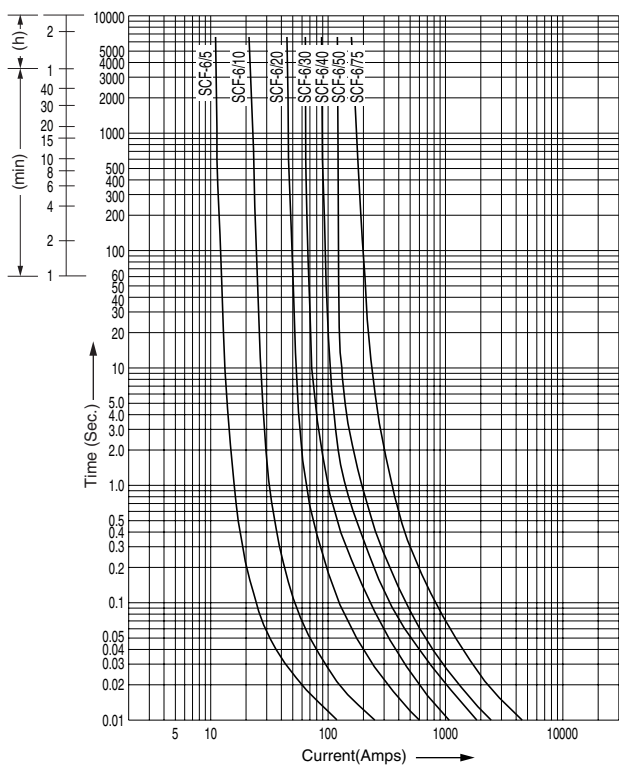

HF-type 3.6 / 7.2kV (E type)

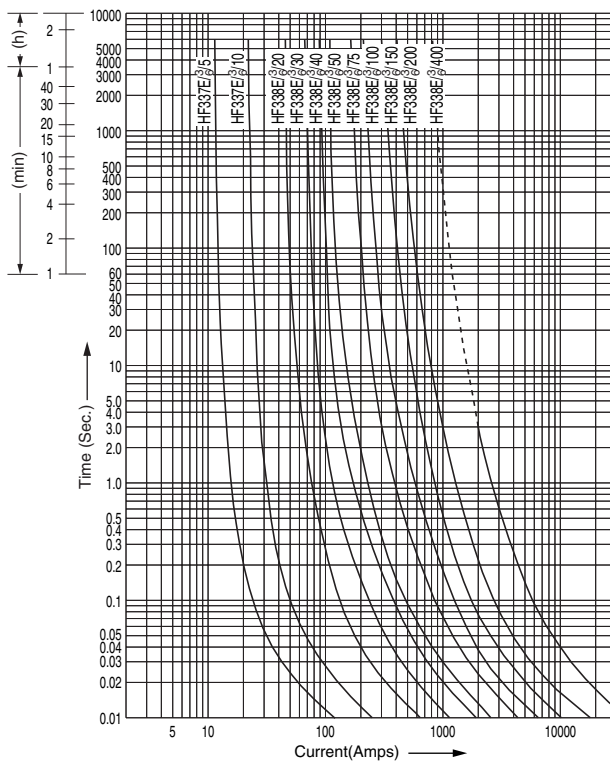

■ **Characteristic curves**

- **Back-up fuses**

Current-limiting characteristic curves

HF-type 12, 24kV

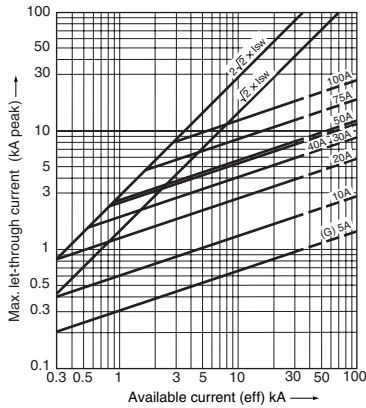

HFB-type 36kV

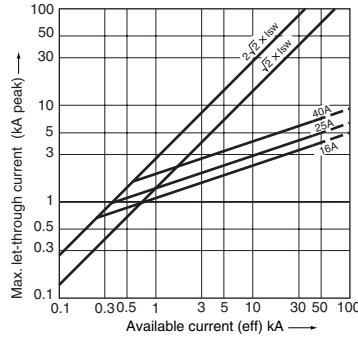

JR-type 36kV

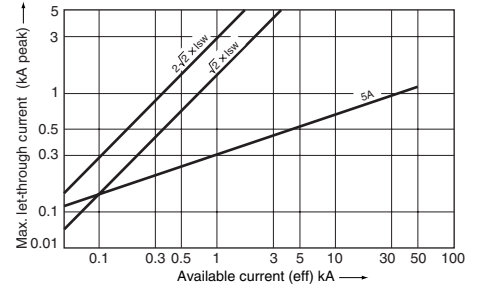

Melting time-current characteristic curves

HF-type 12, 24kV

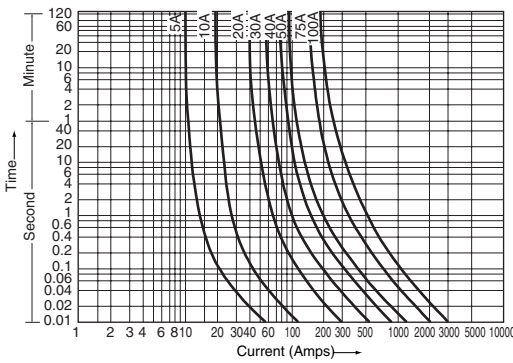

HFB-type 36kV

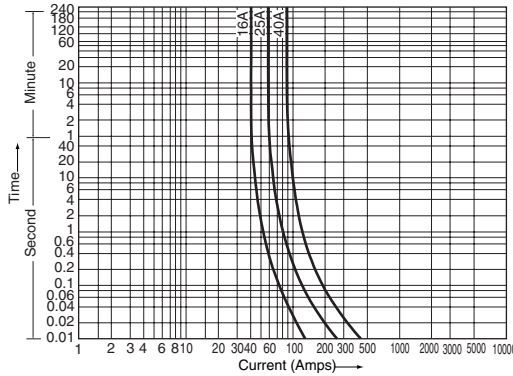

JR-type 36kV

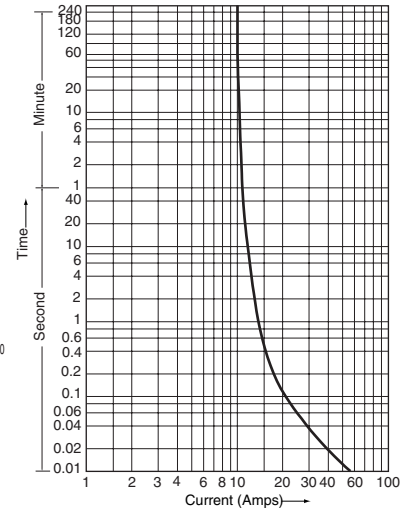

Total clearing (operating) time-current characteristic curves

HF-type 12, 24kV

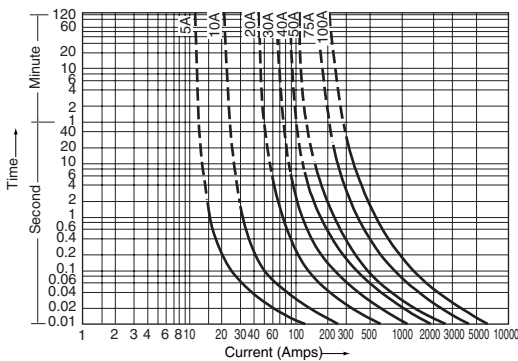

HFB-type 36kV

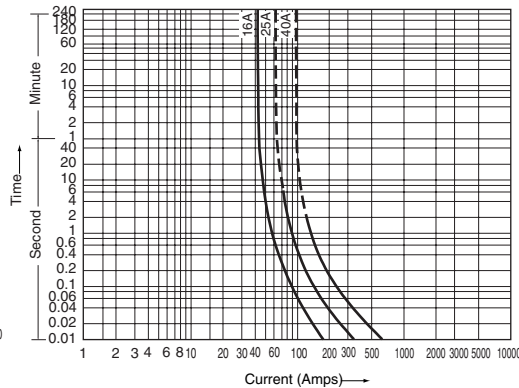

JR-type 36kV

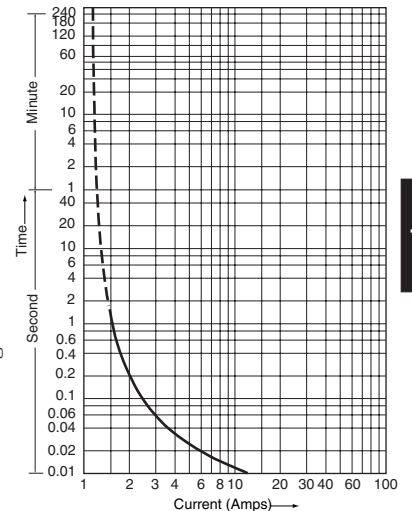

H.V. Distribution Equipment

Fuse holders

SCH & HF340 type

- Dimensions, mm (with fuse links)
- General purpose fuses

Fuse-holder
SCHA-6

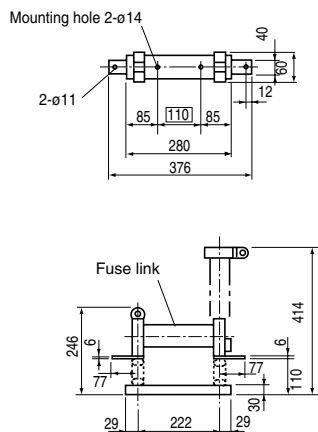

SCH III-6

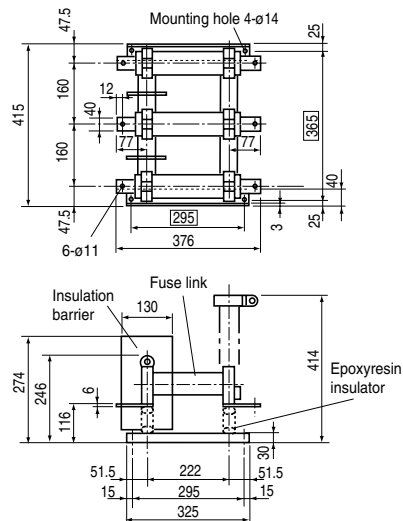

HF-340/6a

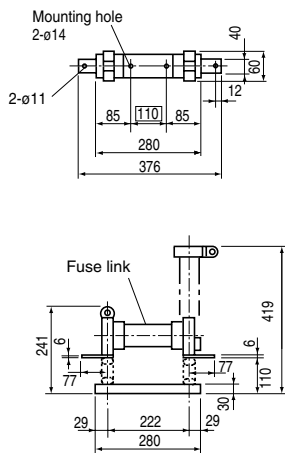

HF340 III/6a

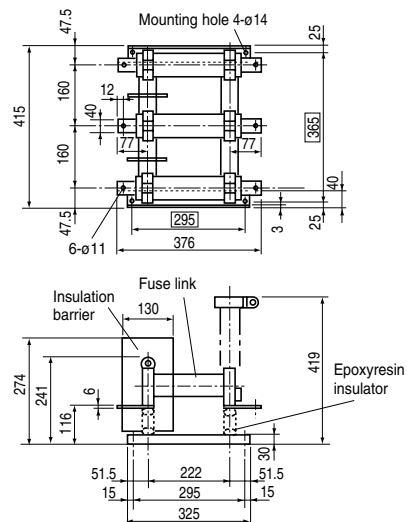

HF340/6b

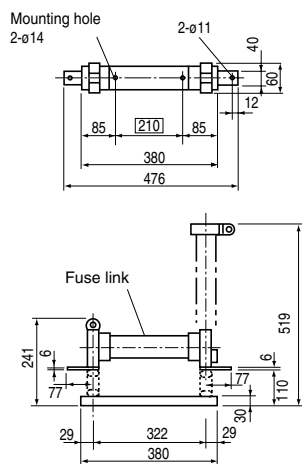

HF340 III/6b

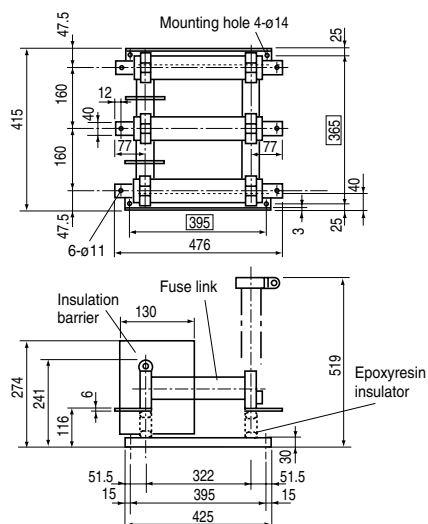

H.V. Distribution Equipment

Fuse holders

HF323 & HF326 type

■ Dimensions, mm

• Back-up fuses (12, 24 and 36kV)

Fuse-holder

HF323

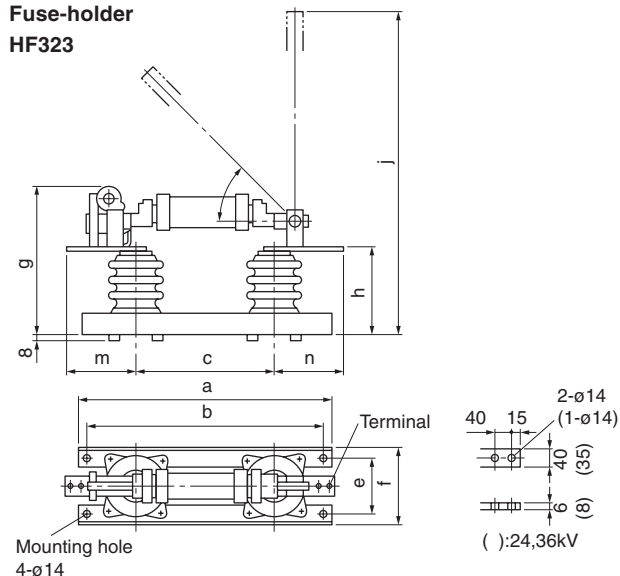

HF323 II

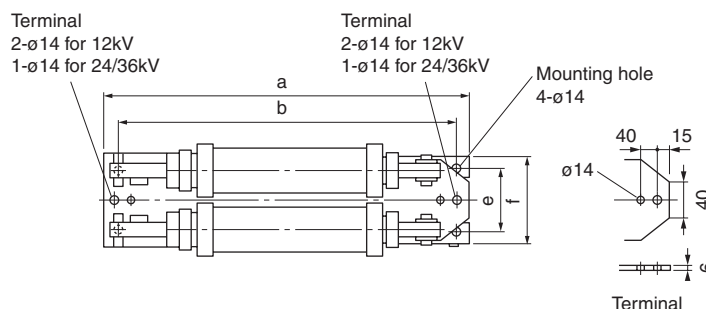

Fuse-holder Type	Rated voltage (kV)	Rated current (A)	a	b	c	e	f	g	h	j	m	n
HF323/10a	12	10	608	568	388	105	155	317	185	776	160	140
HF323/10b	12	20 to 100	758	718	538	105	155	317	185	926	160	140
HF323II/10b	12	150, 200	758	718	538	105	155	317	185	926	111	111
HF323/20	24	10 to 40	788	748	538	130	180	394	260	1001	130	106
HF323II/20	24	80	788	748	538	130	180	394	260	1001	111	111
HF323/30	36	10 to 40	884	844	634	130	180	484	350	1186	130	106
HF323II/30	36	80	884	844	634	130	180	484	350	1186	111	111

HF326

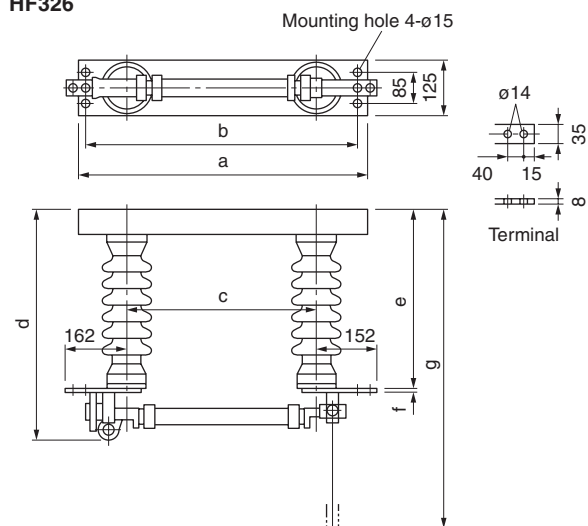

HF326 II

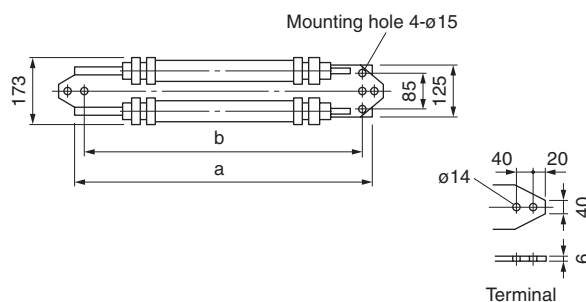

Fuse-holder Type	Rated voltage (kV)	Rated current (A)	a	b	c	d	e	f	g
HF326/10a	12	10	628	588	388	433	309	8	900
HF326/10b	12	20 to 100	778	738	538	433	309	8	1050
HF326II/10b	12	150, 200	778	738	538	433	409	6	1050
HF326/20	24	10 to 40	778	738	538	568	444	8	1185
HF326II/20	24	80	778	738	538	568	444	6	1185
HF326/30	36	10 to 40	874	814	638	698	574	8	1410
HF326II/30	36	80	874	814	638	698	574	6	1410

■ **Dimensions, mm**

General purpose fuses 3.6, 7.2kV

Type	L max.	Dimensions, mm
SCF-6/5 SCF-6/10 SCF-6/20 SCF-6/30 SCF-6/40	274	
SCF-6/50 SCF-6/75	274	
HF337E/6/5 HF337E/6/10	262	
HF338E/6/20 HF338E/6/30	266	
HF338E/6/40 to HF338E/6/200*	366	
HF338E/6/400*	408	
HF337E/3/5 HF337E/3/10	262	
HF338E/3/20 to HF338E/3/100	266	
HF338E/3/150 HF338E/3/200	366	
HF338E/3/400*	408	

*: Back-up fuse
 Mass: [See page 11/18.](#)

■ **Ordering information:** [See page 11/18.](#)

Fuji Electric FA Components & Systems Co., Ltd./D & C Catalog
 Information subject to change without notice

Back-up fuses

Type	L max.	Dimensions, mm
HF337/10/10	362	
HF337/20/10	512	
HF337/30/10	607	
HF338B/10/20 HF338B/10/30 HF338B/10/40 HF338B/10/50 HF338B/10/75 HF338B/10/100 HF338B/20/20 HF338B/20/30 HF338B/20/40	516	
HFB-30/16 HFB-30/25 HFB-30/40	603	
JR-10/5	262	
JR-20/5	362	
JR-30/5	512	

Mass: [See page 11/18.](#)

H.V. Distribution Equipment

Air load break switches

General information

■ Description

- 3.6/7.2kV, 100–600 Amps (LB)
- 3.6/7.2kV, 200 Amps (LBS)
- 12/24/36kV, 600–1200 Amps (RF)

FUJI air load break switch type LBS is provided with current limiting power fuses and type LB is not so fitted. Both types are compact and incorporate arc-extinguishing devices of FUJI's own design. The arc is drawn into a long narrow chamber with close clearances in which the gases are rapidly cooled and dispersed. Contact points therefore wear very slowly, so giving switches a long service life. FUJI air load break switches are recommended for use with power capacitors and transformers.

■ Features

- Excellent arc-extinguishing characteristics
The arc-extinguishing system uses a gas-cooling method. This results in less contact wear than that of comparable oil-immersed types, so ensuring a longer service life and lower maintenance costs.
- Light and compact design
The load break switch and fuses are incorporated into one body and are ideally suited for H.V. cubicle or metal-clad switchgear assembly applications.
- High current-limiting power fuses
The LBS type is provided with FUJI power fuses so ensuring an accurate and uniform interrupting performance.
- Economical first cost
The use of these fuses eliminates the need for circuit breakers with trip mechanisms, and so reduces initial installation costs.
- Safe fuse replacement
Fuses can easily be replaced or changed to different ratings in perfect safety.
- A shunt trip mechanism
A trip mechanism can be attached to LBS and LB having 100 and 200 Amps ratings. It can be tripped remotely.
- Blown fuse indicator
LBS and LB200 to 400 Amps rated switches can be supplied with a blown indicator limit switch attached for remote indication use.
- Auxiliary contacts
All these switches can be attached with 2NO+2NC 15 Amps switches.
- Motor-driven-types available
The standard versions are for stick operation. Motor-driven versions are also available. For further details please contact FUJI.



■ LB type

3.6kV/7.2kV up to 600 Amps 3-pole
3.6kV/7.2kV 200 and 400 Amps 3-pole with power fuse

The LB-type air load break switches are provided with the following major features:

1. They have been down-sized so that they can be installed in compact cubicles.
2. An improved interrupting performance and greater operating safety, achieved through a rotating arc contact and redesigned arc chute.
3. Accessories are built using a modular system, so that power fuse frames, gang-operated mechanisms and auxiliary switches can easily be added to the main switch body as required. These can be fitted in position on site without adjustment.

In addition, the shunt trip mechanism (f) can be incorporated into the basic frame. Previously they were regarded as ↗

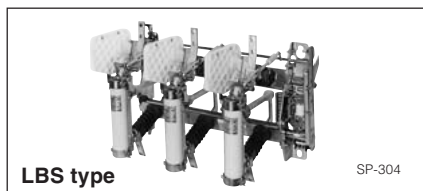

■ LBS-type

3.6/7.2kV, 200 Amps 3-pole

The LBS is an air load break switch with attached power fuses. A striker is incorporated into this unit, a feature which is not found in conventional load break switches.

The striker is a trip mechanism which operates the moment the fuse blows. When this occurs the striker causes all 3-pole to open at the same time. If air load break switches do not have this striker feature it is possible for some of the phases to remain alive after the fuse has blown, so resulting in a dangerous situation. This FUJI feature adds to the safety of the electrical system.

As LBS-type air load break switches are provided with a built-in auto trip mechanism the R290B and R293B remote gang-operated mechanisms cannot be fitted.

accessories. If shunt trip is required f suffix should be added to the type number when ordering.

Shunt trip mechanisms are factory-fitted before shipment. Please note that the R290B or R293B remote gang-operated mechanism cannot be incorporated with these shunt trip mechanisms. Those LB-type air load break switches of 200AF and 400AF can be fitted with power fuses. However, even if the LB-type units have 400AF ratings, power fuses up to 200 Amps only are required.

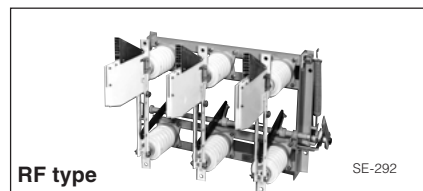

■ RF-type

12/24/36kV up to 1200 Amps 3-pole

The RF-type load break switch consists of a main blade, an auxiliary blade and an arc chute. The auxiliary blade is located at the arc chute and connected with the main blade. It will make contact at the same time as the main blade. The auxiliary blade will be momentarily held in contact in the arc chute at the time when the main blade opens. Once the main blade has reached the limit of travel the auxiliary blade will rapidly return to its position against the main blade under the influence of stored energy in the spring. This quick-break device functions effectively even when manually operated, and since the contact moves at high speed the arc is rapidly elongated and gas-cooled in the arc chute.

■ **General specification of switch body**

Description	LBS type		LB type					
	LBS-6/200	LBS-6/210 LBS-6/200f	LBS-6/210 LBS-6/210f	without shunt trip device			with shunt trip device	
			LB-6/100	LB-6/200	LB-6/400	LB-6/600	LB-6/100f	LB-6/200f
Rated	Voltage (kV)	7.2/3.6	7.2/3.6	7.2/3.6	7.2/3.6	7.2/3.6	7.2/3.6	7.2/3.6
	Current (A)	200	200	100	200	400	600	200
	Short-time current (1 sec.) (kA)	—	—	4	8	12.5	8	4
	Making short-circuit current (kA)	—	—	10	20 ¹	31.5 ¹	20 ¹	10
	Frequency (Hz)	50/60	50/60	50/60	50/60	50/60	50/60	50/60
Insulation	Dielectric strength (1 minute) (kV)	22	22	22	22	22	22	22
	BIL (1.2 × 50μs) (kV)	60	60	60	60	60	60	60
Main active load breaking capacity (A)	200	200	100	200	400	200	100	200
Cable charging breaking capacity (A)	10	10	10	10	10	10	10	10
Transformer off load breaking capacity (A)	10	10	5	10	20	10	5	10
Capacitor breaking current (A)	30	30	30	30	50	30	30	30
Fuse	Holder with blown indicator	—	—	—	FH-2	FH-2	—	—
	Holder without blown indicator	—	—	—	FH-1	FH-1	—	—
	Link	JC-6 ⁴	JC-6 ⁵	—	HF337E	HF337E	—	—
	Interrupting capacity (kA)	40	40	—	40 ³	40 ³	—	—

Description	RF250 type		RF248 type		
	RF250III/ 20/600	RF250III/ 20/600	RF248III/ 20/600	RF248III/ 20/1200	RF248III/ 30/600
Rated	Voltage (kV)	12/24	12/24	12/24	36
	Current (A)	600	600	1200	600
	Short-time current (1 sec.) (kA)	22	22	27	22
	Making short-circuit current (kA)	40	40	40	40
	Frequency (Hz)	50/60	50/60	50/60	50/60
Insulation	Dielectric strength (1 minute) (kV)	50	50	50	70
	BIL (1.2 × 50μs) (kV)	125	125	125	170
Main active load breaking capacity (A)	600	75	75	50	50
Cable charging breaking capacity (A)	20	20	20	15	15
Transformer off load breaking capacity (A)	20	10	10	10	10
Closing loop breaking capacity (A)	600	75	75	50	50

Note: *1: 20kA when operated by R290-B.
 10kA when operate by R293B.

*2: 200A is maximum for fuse-link.
 *4: 75A is maximum for fuse-link.

*3: 31.5kA when 200A power fuse is used at 7.2kV.
 *5: 100A is maximum for fuse-link.

LBS and LB types

■ **Construction**

Arc extinguishing chute
 FUJI new LBS and LB type airload break switches are compact and have superior safety characteristics. This is mainly due to the newly-developed arc extinguishing chamber.

■ **Features**

- The arc extinguishing chute is so designed that it is enclosed on three sides and the arc-extinguishing method uses a "narrow-gap arc-extinguishing method". Since the chute is closed in three directions the arcs and ionized gas are not dispersed to the back thus ensuring safety. Moreover, the gap of the arcing chamber is narrow so enabling the high temperature gas to be abruptly cooled thus ensuring a highly efficient extinction of arc.
- Ω shaped rotary movable blade arc contacts are employed. These contacts are designed to carry out the interruption while rotating. This design is aimed at improving the interrupting performance, and as arcs are not ejected in the direction of the operator there is greater safety.
- The contacts use a tandem method in which an arc contact and a main contact

are provided for each pole.
 The operation is carried out as follows:
 When the LB switch is interrupted at high speed the load current is commutated to the arc contact immediately before the main contact being opened.

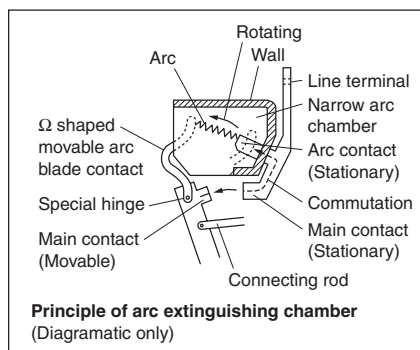

■ **Shunt trip mechanism**

The shunt trip mechanism will trip the LB switch when a 100V AC or DC is applied to the coil. This enables tripping to be carried out from a distance. The trip coil for AC use has a continuous rating and power consumption is 50VA.

The trip coil for DC use has a short-time rating of 5 secs.

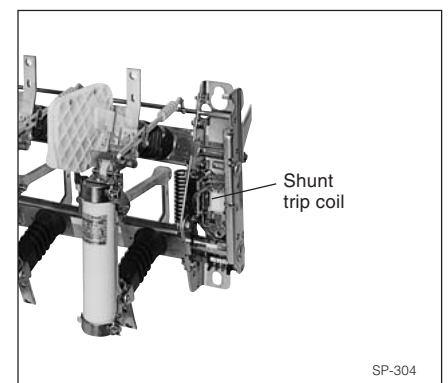

Ratings

Switch body	Coil ratings	Operating time
LBS-6/200f	100/110V AC•DC	0.1 sec.
LBS-6/210f	3A	
LB-6/100f	AC: Continuous	
LB-6/200f	DC: 5 sec.	

H.V. Distribution Equipment

Air load break switches

Accessories/LB type

■ Accessories/LB type

● Auxiliary switches/AUX-3, AUX-4

The auxiliary switches are available in AUX-3 and AUX-4 types. The AUX-3 is designed to be fitted to 100AF LB switches and AUX-4 to 200AF and above. The AUX-3 and AUX-4 auxiliary switches are available in kits which consist of a switch body (2NO + 2NC), mounting and connecting lever and screws. They can be used for open-close indication and interlocking circuits.

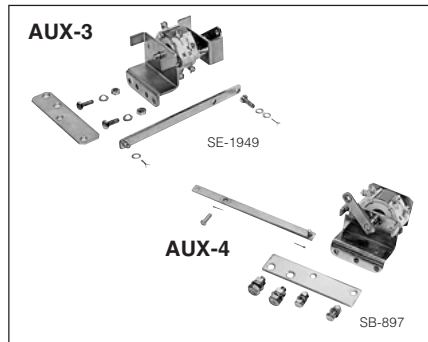

Type	Use with	Rated	Contact arrangement
AUX-3	100A frame	100/110V DC 15A	23 33 21 31
AUX-4	200A to 600A frames	200/220V AC 15A	22 32 20 30

● Left-hand lever handle/LB-LH

LB switches with ratings of 200AF and above can be fitted with operating handles on the left hand side. Use LB-LH handle in this case which is sold separately. Please note that the lever for right handle use must not be fitted on the left-hand side as this would not allow sufficient safety distance. If left handed handled switches are required for switches of 200AF and above with shunt trip mechanism they must be modified at the FUJI factory. In this case specify LB-6/200fL when ordering.

The standard type handle (Right) and the LB-LH left handle lever (Left).

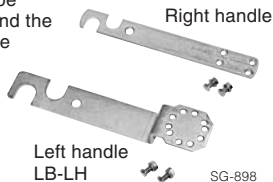

Standard type LB-6/200

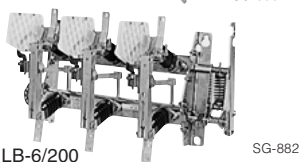

This shows a LB-6/200 switch fitted with a LB-LH handle.

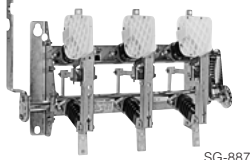

● Gang-operated mechanism

Normally switching is carried out by a stick, but remote control can be carried out either manually or by a motor-driven mechanism. Contact FUJI for details.

● Manual operating mechanism

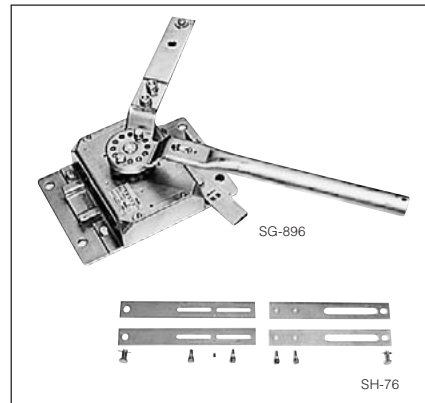

Type	Interlock coil Unlock coil energized	Lock coil energized	Contact for crank handle
R290-B	-	-	-
R290-BDS	100/110V DC, 0.1A	-	1NC (110V DC, 1.3A)
R290-BAS	100/110V AC, 0.1A	-	1NC 110V DC, 1.3A)
R290Z-BAS	-	100/110V AC, 0.1A	1NC (110V DC, 1.3A)

● Motor-driven mechanism

Type	Motor ratings
R293B-1	100/110V AC DC 8.8A
R293B-2	200/220V AC DC 4.4A

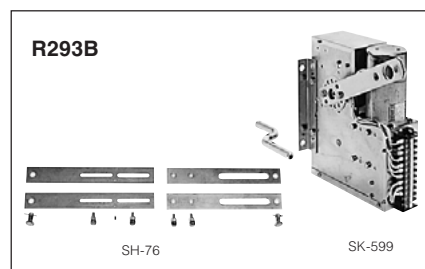

● Control unit for motor-driven mechanism

R293X is a control unit with a motor-driven mechanism. It consists of two industrial relays and all that is necessary to connect it to the motor unit or an on-off switch.

For the connection diagram, refer to [Page 11/33](#).

Type	Operating voltage	Use with
R293X-1	100/110V AC	R293B-1
R293X-2	200/220V AC	R293B-2
R293X-3	100/110V DC	R293B-1

R293X

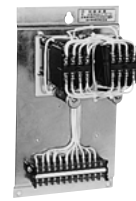

● Fuse holders/FH-1, FH-2

These holders are for attaching power fuses to air load break switches. The FH-1 holders fit the 3-pole holder frame only. The FH-2 holders are fitted with fuse blown indicating switches (SPDT). LB switches with ratings of 200A and 400A only can be fitted with these holders. The holders accept FUJI HH fuses with ratings from 5A to 200A. When 100AF switches with power fuses are required, use the LBS type. The appropriate fuse type is the JC series. Max. 200A power fuse can be fitted to 200AF and 400AF switches. Fuse-links are available with overall lengths of either 266mm or 366mm. However, if the position of the hole on the frame is changed either of these fuses can be fitted.

Type	Contact ratings	Use with
FH-1	-	200, 400A frame
FH-2	100V DC 0.6A 110V AC 6A 220V AC 6A (Inductive load)	11 12 13

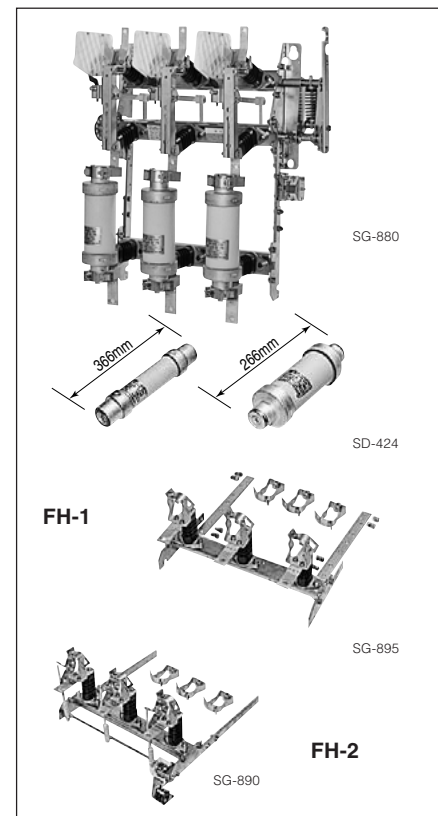

■ **Accessories/LBS type**
 ● **Shunt trip mechanism**

This mechanism permits remote tripping and when a 100V DC or AC is applied to the trip coil an interruption is carried out. It has a continuous rating when used with AC but a short time rating of 5 secs when connected to a DC supply. Please connect the auxiliary contacts (1NO) on the LBS switches in series in order to prevent the coil from being burnt when operating on DC. Specify "LBS-6/200F" or "LBS-6/210F" when ordering and switches will be shipped with trip mechanism factory-assembled.

Coil ratings	Operating time
100/110V AC•DC 3A AC: Continuous DC: 5 sec.	0.1 sec. or less

● **Auxiliary switches/AUX-3**

These switches provide an open-closed indication and can be used for interlocking circuits. The AUX-3 type auxiliary switches are sold as separate kits. They are easily fitted to the switch body and are supplied with instruction manual. The contact arrangement is 2NO + 2NC.

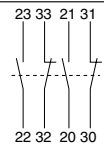
Type	Ratings	Arrangement
AUX-3	100/110V DC 15A 200/220V AC 15A	

● **Blown-fuse indicators/AL-3B**

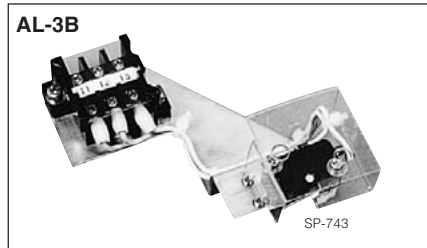

The AL-3B will provide an alarm when a fuse is blown.

These units are easily fitted to the LBS switches. The contact arrangement is SPDT and it has a momentary action of 25ms. It, therefore, requires a self-hold circuit as shown in the diagram.

● **Contact specification**

Arrangement	SPDT
Ratings (Inductive load)	100V DC 0.6A, 110V AC 6A, 220V AC 6A
Signal continuous time	25 ms

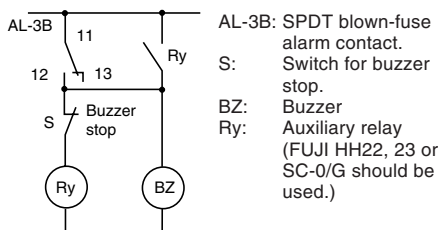

● **Power fuses JC-6/5 to JC-6/100**



LBS switches require fuses and these are sold separately. Power fuses are selected to meet the load requirements and prices differ according to the ampere ratings. It is therefore necessary to specify the fuse rating when LBS switches are ordered. The fuses are shipped in cartons holding a set of three pieces. The following table lists fuse ratings for general use.

Type	Ratings		
	Voltage (kV)	Interrupting current (kA)	Rated* current (A)
JC-6/5	7.2/3.6	40.0	5
JC-6/10			10
JC-6/20			20
JC-6/30			30
JC-6/40			40
JC-6/50			50
JC-6/60			60
JC-6/75			75
JC-6/100			100

* General purpose (G-type)

● **Barriers**



The LBS switches have an adequate insulation distance and when installed in the metal-enclosed cubicles barriers are not required. When used in open-type cubicles or under "open" conditions barriers can be supplied to prevent damage from small animals occurring. These are sold separately.

Type	Number of barriers
SP-4C	4



With SP-4C barriers

H.V. Distribution Equipment

Air load break switches

■ Attachment accessories and modification kits

Switch body type	Shunt trip	Auxiliary switch	Operating mechanism			Left lever handle	Power fuse link	Fuse holders	
			Manual remote operating	Motor driven remote operating	Control unit			Without blown indicator	With blown indicator
LBS-6/200	–	▲AUX-3	–	–	–	–	▲JC-6/□	●	▲AL-3B
LBS-6/200f	●		–	–	–	–	▲JC-6/□	●	▲AL-3B
LBS-6/210	–	▲AUX-3	–	–	–	–	▲JC-6/□	●	▲AL-3B
LBS-6/210f	●		–	–	–	–	–	–	–
LB-6/100	–	▲AUX-3	–	–	–	–	–	–	–
LB-6/100f	●		–	–	–	–	–	–	–
LB-6/200	–	▲AUX-4	▲R290B	▲R293B	▲R293X	▲LB-LH	▲HF337	▲FH-1	▲FH-2
LB-6/200f	●		–	–	–	–	HF338		
LB-6/200fL	●		–	–	–	●	–		
LB-6/400	–		▲R290B	▲R293B	▲R293X	▲LB-LH	–		
LB-6/600	–		–	–	–	–	–		

Note: ● Factory assembled ▲ Customer assembled – Not available



LB-6/100

SG-879

● LB type

No. of pole	Rated voltage (kV)	Rated current (A)	Shunt trip	Handle attaching angle	Mass (kg)	Type
3	7.2/3.6	100	–	Fixed	9	LB-6/100
		100	Provided	Fixed	9.5	LB-6/100f
	7.2/3.6	200	–	Adjustable	11	LB-6/200
		200	Provided	Fixed	14	LB-6/200f
		200	Provided	Fixed	15	LB-6/200fL
7.2/3.6	400	–	Adjustable	12	LB-6/400	
7.2/3.6	600	–	Adjustalbe	14	LB-6/600	



LBS type
Compact size

SP-304

● LBS type

No. of pole	Rated voltage (kV)	Rated current (A)	Shunt trip	Handle attaching angle	Mass (kg)	Type	Fuse rated current
3	7.2/3.6	200	–	Fixed	10	LBS-6/200	Type JC: 5 to 75A
		200	Provided	Fixed	10.5	LBS-6/200f	
3	7.2/3.6	200	–	Fixed	10	LBS-6/210	Type JC: 100A
		200	Provided	Fixed	10.5	LBS-6/210f	

■ Ordering information

Specify the following:

1. Type number or ordering code
2. Attachment accessories and modification kits if required.

Example (Type number)

- LB-type air load break switch LB
- Rated voltage 7.2kV –6
- Rated current 200 A 200
- With shunt trip device f

Type number LB-6/200f
and

Type number of fuse link HF338E/6/75
(Rated current 75 A)

Fuse holder with fuse blown indicator FH-2

■ Type number nomenclature

LB - 6 / 200 f L

Handle

Blank: Standard (Right lever handle)

L: Left lever handle (200A only)

Shunt trip device

Blank: Without shunt trip device

f: With shunt trip device

Rated current

100: 100A

200, 210: 200A

400: 400A

600: 600A

Rated voltage

6: 7.2/3.6kV

Basic type

LB or LBS

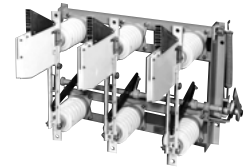

SE-292

● RF type 12kV to 36kV

No. of poles	Ratings			Auxiliary switch	Operating motor ratings Type R294/10D200	Type	Mass (kg)
	Voltage (kV)	Current (A)	Making & breaking current (A)				
3	12/24	600	75	—	—	RF248III/20/600	105
				2NO+2NC	—	RF248III/20/600W	105
				2NO+2NC *	100/110V DC 32.6A (max.)	RF248III/20/600GW	105
	1200	75	75	—	—	RF248III/20/1200	125
				2NO+2NC	—	RF248III/20/1200W	125
				2NO+2NC *	100/110V DC 32.6A (max.)	RF248III/20/1200GW	125
600	600	600	—	—	RF250III/20/600	105	
			2NO+2NC	—	RF250III/20/600W	105	
			2NO+2NC *	100/110V DC 32.6A (max.)	RF250III/20/600GW	105	
36	600	50	—	—	RF248III/30/600	140	
			2NO+2NC	—	RF248III/30/600W	140	
			2NO+2NC *	100/110V DC 32.6A (max.)	RF248III/30/600GW	140	

Note: * 2NO+2NC auxiliary contact required for internal wiring purpose.

■ Ordering information

Specify the following:

1. Type number or ordering code

■ Type number nomenclature

RF 250 III/6/600 □ W

Basic type

RF250, RF248

Poles

III: 3-pole

Rated voltage

20: 12/24kV
30: 36kV

Auxiliary switch

Blank: Without auxiliary switch

W: With auxiliary switch (2NO+2NC)

Operating

Blank: Stick-operated

G: Manual remote-operated by R290-B

Motor remote-operated by R294/10D200

Rated current

600: 600A

1200: 1200A

■ Dimensions, mm

● LB-6/100

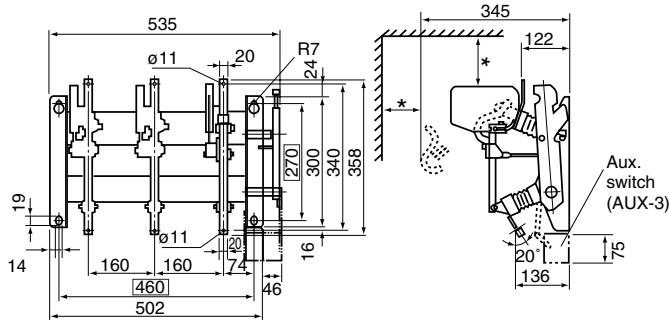

● LB-6/100f

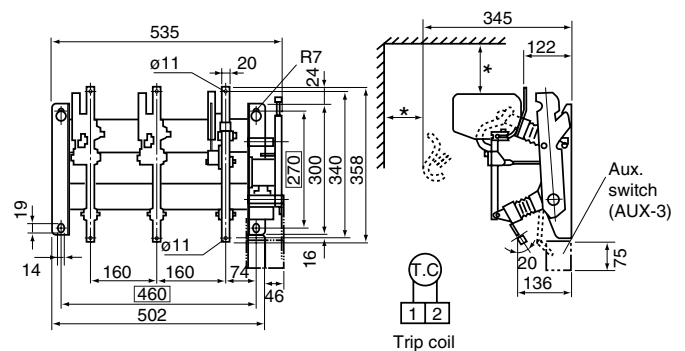

* Arc space: Over 100mm
For other LB types, arc space (over 100mm) is necessary.

■ Dimensions, mm/Gang-operated mechanism
 • R290-B

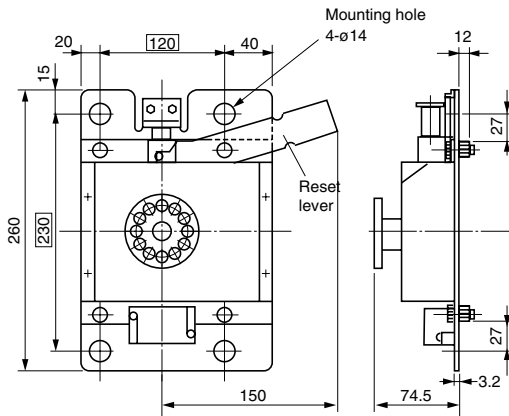

• R293X

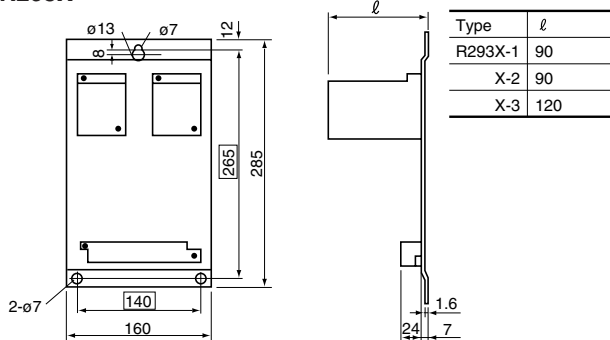

• R293B

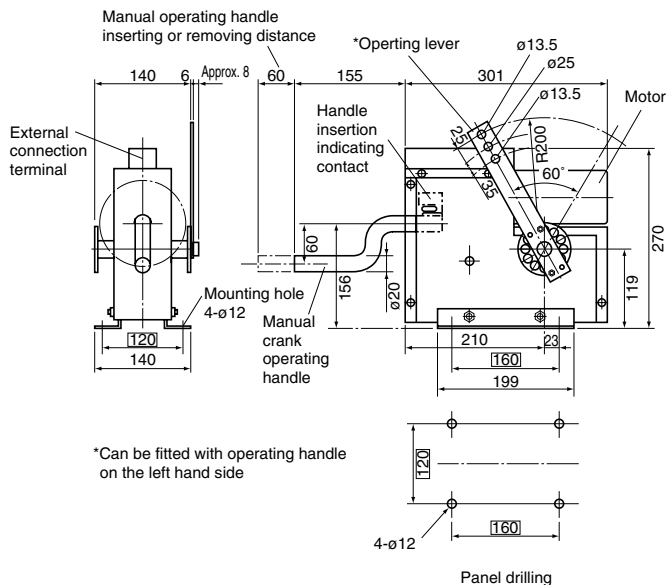

■ Wiring diagrams
 • R290-BDS

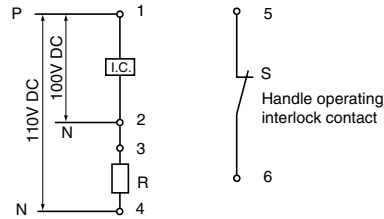

• R290-BAS, R290Z-BAS

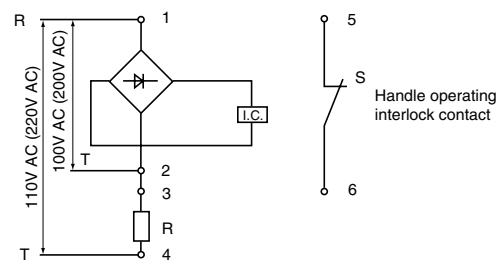

• R293B, R293X

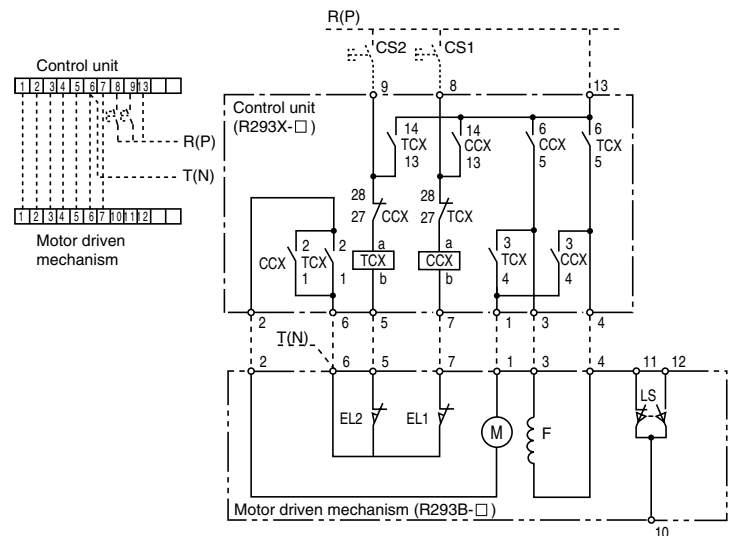

- CS1 : ON switch (Not supplied)
- CS2 : OFF switch (Trip) (Not supplied)
- CCX : Magnetic contactor for closing
- TCX : Magnetic contactor for tripping
- EL1 : End limit switch for closing
- EL2 : End limit switch for tripping
- F : Motor/armature
- M : Motor/armature
- LS : Crank handle insertion indicating contact
- 10-11 ON: Removing handle
- 10-12 ON: Inserting handle

Note: For gang-operated diagrams, contact FUJI.

H.V. Distribution Equipment

Air load break switches

LBS type

■ Dimensions, mm

• LBS-6/200, 200f

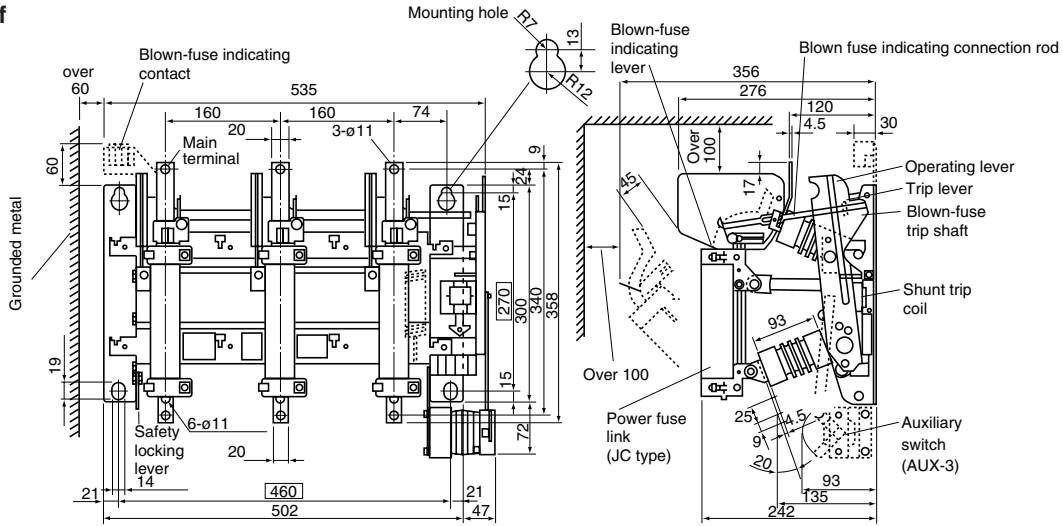

• LBS-6/210, 210f

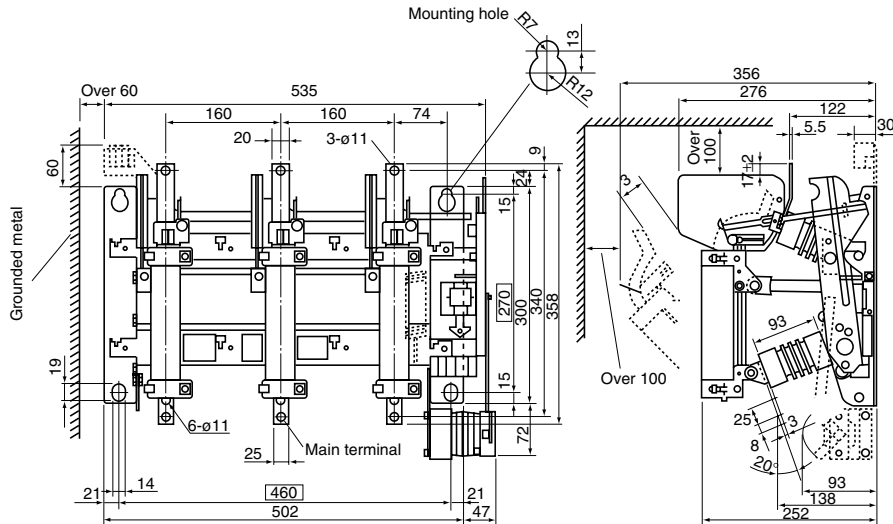

• Accessories

- Fuse link

■ Wiring diagrams (Shunt trip operating circuit)

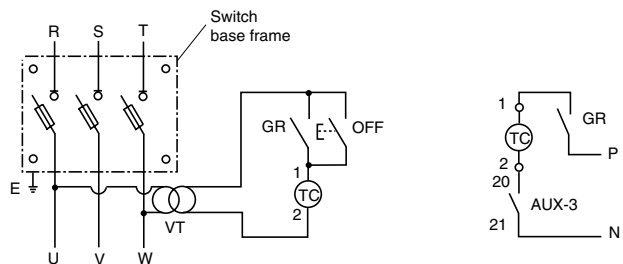
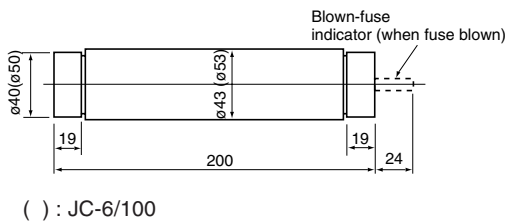

AC operating

DC operating

■ Dimensions, mm
 • RF250III/20/600

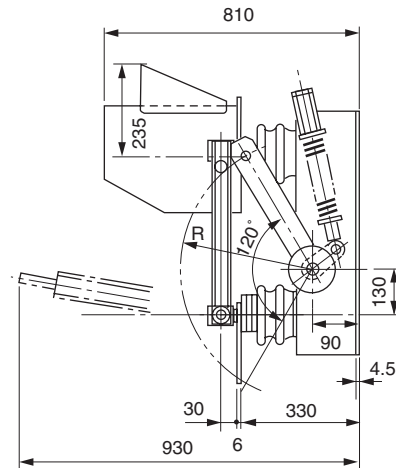
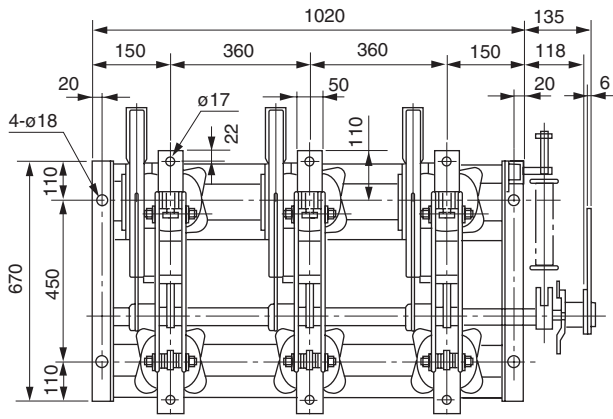

• RF248III/20/600

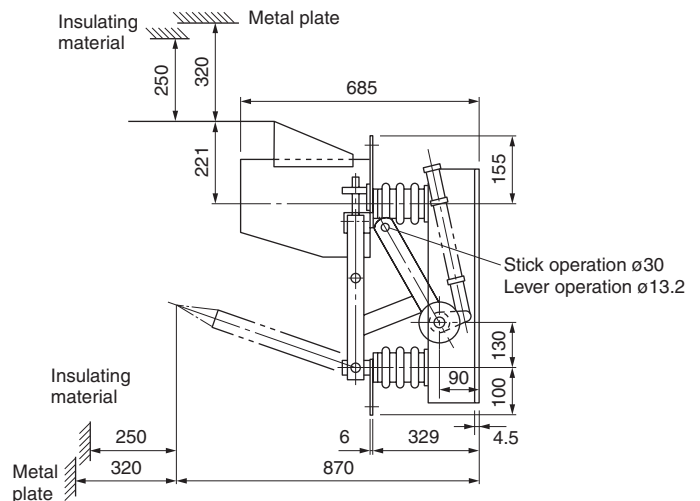
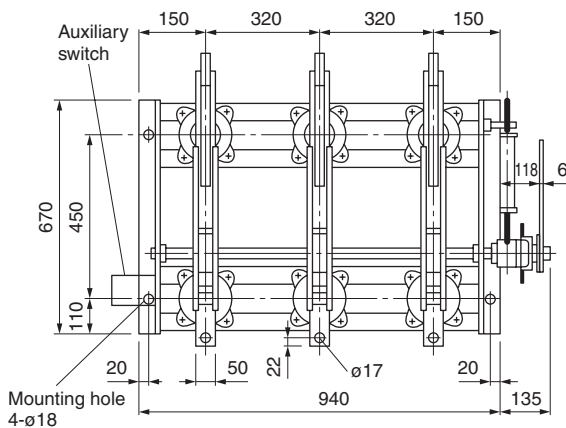

• RF248III/20/1200

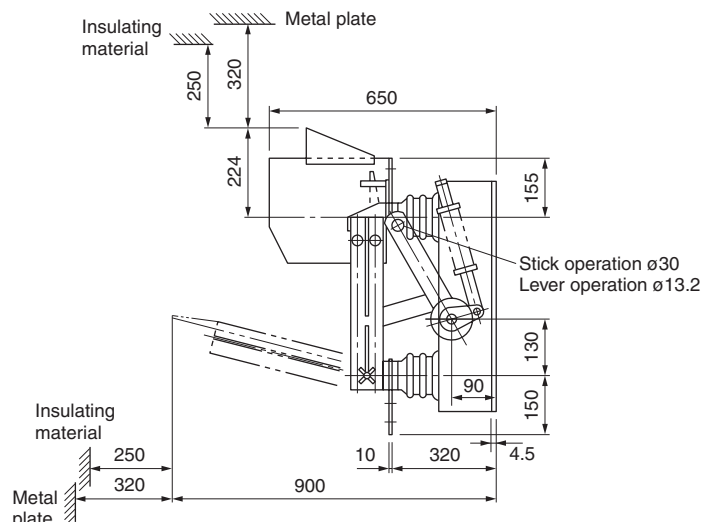
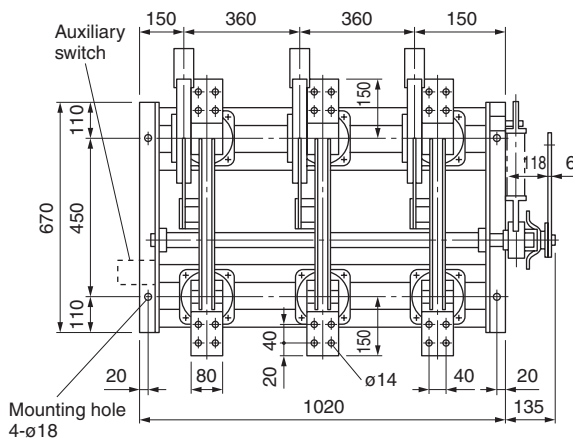

VT and CT

3.45/6.9/11.5/23/34.5kV
Up to 5000 Amps

■ Description

Fuji epoxy resin molded type CT and VT feature excellent water- and damp-proof characteristics. There is no danger of insulation deterioration. Their good thermal and mechanical performance make them suitable for a wide range of applications, while the initial cost of VT and CT are very reasonable.

■ Features

- Accuracy: Class 1.0
- No corona is produced.
- FUJI's advanced manufacturing techniques eliminate cracking of molded enclosure.
- VT is provided with a current-limiting fuse to give a large interrupting capacity.

■ Selection note

1. Primary current of CT must be 150% of the load current of measuring.
2. Rated overcurrent constant must be considered when used for circuit protection.
3. Accuracy class, rated burden and maximum voltage.
4. When determining VA, add secondary wiring or cabling burden.

■ General specifications

Current transformer (CT)

- Accuracy class: 1.0
- Maximum voltage: Up to 34.5kV
- Rated frequency: 50/60Hz
- Secondary current: 5A

Voltage transformer (VT)

- Accuracy class: 1.0
- Maximum voltage: Up to 33kV
- Rated frequency: 50/60Hz
- Secondary voltage: 110V

■ Current transformers



RC15-6C

RC15-6C



N33-142-12

CE3-10

● **Epoxy resin molded CT NCE, CEC, CEA and CE types**
NCE, CEC and CEA are used in distribution circuits of up to 6.9kV. Only the primary and secondary windings are molded in epoxy resin. CE type is designed for use in circuits between 11.5 – 34.5kV. Iron core windings, terminal stand and insulation are all integrated into one body and encapsulated with epoxy resin in a vacuum. The iron core is fabricated from silicon steel plate which ensures an excellent electrical performance. The corona and insulating characteristics are excellent so assuring a long service life. There is no fear of the epoxy resin cracking. The transformer is compact in design and takes up little space on installation.

RC15 type: 5/5–750/5 Amps, 6.9kV
NCE type: 10/5–400/5 Amps, 6.9kV
CEC type: 10/5–200/5 Amps, 6.9kV
CEA type: 300/5–2000/5 Amps, 6.9kV
CE type: 50/5–5000/5 Amps,
11.5–34.5kV

■ **Types and ratings:** [See pages 11/39 and 11/41.](#)

■ **Dimensions:** [See pages 11/42 to 11/44.](#)

■ Voltage transformers



CP-624

NPE12-6FA



N33-142-12

PE4-30

● **Epoxy resin molded VT NPE, PEC and PE types**

These types have both primary and secondary windings molded in epoxy resin. The insulating resin is also strong against chemical attack which makes the transformer suitable for use in chemical plants and other similar locations. PE type has windings, core and terminals incorporated into one body. It can be used for measuring voltages in the 11kV–33kV range.

■ **Types and ratings:** [See pages 11/40.](#)

■ **Dimensions:** [See pages 11/45.](#)

H.V. Distribution Equipment

Instrument transformers

General information

■ Selection table/CT

Maximum voltage	3.45/6.9kV	11.5kV	23kV	34.5kV
Type	RC15-6C (5–750A) NCE2-6B (10–400A) CEC1-6M (10–200A) CEA1-6M (300–2000A)	CE3-10 (50–1200A) CE5-10 (1500–2000A) CE2-10 (1500–4000A) CE6-10 (5000A)	CE1-20 (50–1200A) CE5-20 (1500–2000A) CE2-20 (1500–4000A) CE6-20 (5000A)	CE4-30 (50–1200A)

■ Selection table/VT

Voltage class	3kV	6kV	10kV	15kV	20kV	30kV
Type	NPE12-3FA (50VA) NPE12-3FA (100VA) PEC2-3FA (200VA)	NPE12-6FA (50VA) NPE12-6FA (100VA) PEC2-6FA (200VA)	PE10-10 PE11-10	PE10-15	PE12-20	PE4-30

■ Ordering information

Current transformer (CT)

Specify the following:

1. Type number
2. Rated voltage
3. Rated primary current
4. Rated secondary current
5. Rated frequency
6. Rated burden
7. Accuracy class

Voltage transformer (VT)

Specify the following:

1. Type number
2. Rated primary voltage
3. Rated secondary voltage
4. Rated frequency
5. Rated burden
6. Accuracy class

■ Type number nomenclature

● Current transformer
Up to 6.9kV

CEC1-6M/100

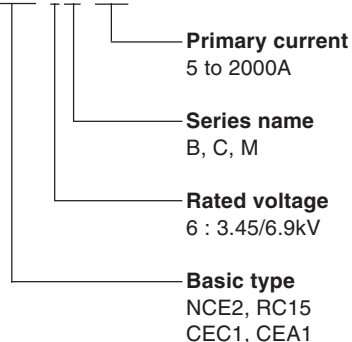

● Voltage transformer
Up to 6.6kV

NPE12-3FA/50

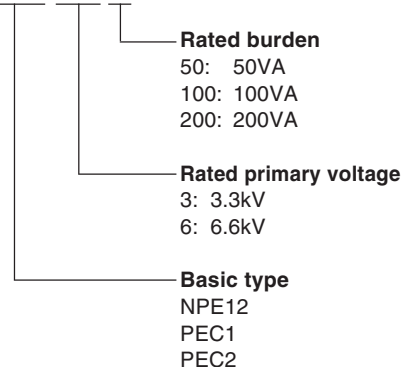

11.5 to 34.5kV

CE3-10

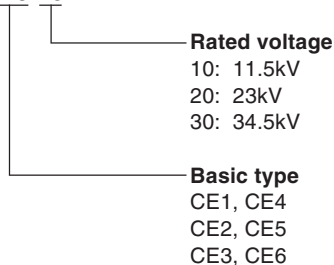

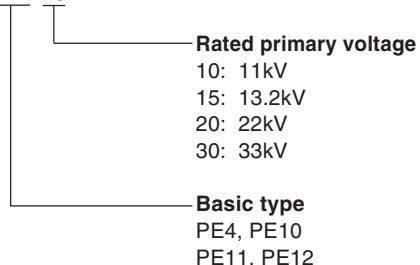

11 to 33kV

PE4-10



■ Types and ratings CT 3.45/6.9kV

Illustration	Max. voltage (kV)	Primary/Secondary current (A)	Type	Withstand current (kA/1s)	Mass (kg)	Technical information
 <p>RC15-6C RC15-6C</p>	6.9 (3.45 common use)	5/5	RC15-6C/5	0.2	4.5	<ul style="list-style-type: none"> • Rated overcurrent constant (n): n > 10 (at burden 10VA) n > 5 (at burden 20VA) • Rated burden: 40VA • Accuracy class: 1.0 Insulation level Withstand voltage (AC 1min.) Primary: 22kV, Secondary: 2kV Basic-impulse insulation level: 60kV (full wave)
		10/5	RC15-6C/10	0.4	4.5	
		15/5	RC15-6C/15	0.6	4.5	
		20/5	RC15-6C/20	0.8	4.5	
		30/5	RC15-6C/30	1.2	4.5	
		40/5	RC15-6C/40	1.6	4.5	
		50/5	RC15-6C/50	2	4.5	
		60/5	RC15-6C/60	2.4	4.5	
		75/5	RC15-6C/75	3	4.5	
		100/5	RC15-6C/100	4	4.5	
		150/5	RC15-6C/150	6	4.5	
		200/5	RC15-6C/200	8	4.5	
		300/5	RC15-6C/300	12	4.5	
		400/5	RC15-6C/400	16	4.5	
		500/5	RC15-6C/500	20	4.5	
600/5	RC15-6C/600	24	4.5			
750/5	RC15-6C/750	30	4.5			
 <p>SH-1045 CEC1-6M</p>	6.9 (3.45 common use)	10/5	NCE2-6B/10	0.4	7.5	<ul style="list-style-type: none"> • Rated overcurrent constant (n): n > 10 • Rated burden: 40VA • Accuracy class: 1.0 • Insulation level Withstand voltage (AC 1min.) Primary: 22kV, Secondary: 2kV Basic-impulse insulation level: 60kV (full wave)
		15/5	NCE2-6B/15	0.6	7.5	
		20/5	NCE2-6B/20	0.8	7.5	
		30/5	NCE2-6B/30	1.2	7.5	
		40/5	NCE2-6B/40	1.6	7.5	
		50/5	NCE2-6B/50	2	7.5	
		75/5	NCE2-6B/75	3	7.5	
		100/5	NCE2-6B/100	4	7.5	
		150/5	NCE2-6B/150	6	7.5	
		200/5	NCE2-6B/200	8	7.5	
 <p>SH-1046 CEA1-6M</p>	6.9 (3.45 common use)	10/5	CEC1-6M/10	2.5	12	<ul style="list-style-type: none"> • Rated overcurrent constant (n): n > 10 • Rated burden: 25VA • Accuracy class: 1.0 • Insulation level Withstand voltage (AC 1min.) Primary: 22kV, Secondary: 2kV Basic-impulse insulation level: 60kV (full wave)
		15/5	CEC1-6M/15	3.75	12	
		20/5	CEC1-6M/20	5	12	
		30/5	CEC1-6M/30	7.5	12	
		40/5	CEC1-6M/40	10	12	
		50/5	CEC1-6M/50	12.5	12	
		75/5	CEC1-6M/75	18.75	12	
		100/5	CEC1-6M/100	25	12	
		150/5	CEC1-6M/150	25	12	
		200/5	CEC1-6M/200	25	12	
		300/5	CEA1-6M/300	25	10	
		400/5	CEA1-6M/400	25	10	
		500/5	CEA1-6M/500	25	10	
		600/5	CEA1-6M/600	25	10	
		750/5	CEA1-6M/750	25	10	
		1000/5	CEA1-6M/1000	25	10	
		1200/5	CEA1-6M/1200	25	10	
		1500/5	CEA1-6M/1500	25	10	
2000/5	CEA1-6M/2000	25	10			

H.V. Distribution Equipment





Instrument transformers

■ Types and ratings VT 3300V – 33000V

Illustration	Primary/Secondary voltage (V)	Rated burden (VA)	Type	Interrupting capacity of fuse	Mass (kg)	Technical information
 <p>CP-624 NPE12</p>	3300/110	50	NPE12-3FA/50	40kA*1	8.5	<ul style="list-style-type: none"> • Accuracy class: 1.0 • Insulation level <ul style="list-style-type: none"> NPE12-3FA } BIL 45kV*2, 16kV AC PEC2-3FA } NPE12-6FA } BIL 60kV, 22kV AC PEC2-6FA } PE11-10 } BIL 90kV, 28kV AC PE10-10 } PE10-15 } BIL 95kV, 34kV AC PE12-20 } BIL 125kV, 50kV AC PE4-30 } BIL 170kV, 70kV AC
	6600/110	50	NPE12-6FA/50	40kA*1	8.5	
	3300/110	100	NPE12-3FA/100	40kA*1	8.5	
	6600/110	100	NPE12-6FA/100	40kA*1	8.5	
	3300/110	200	PEC2-3FA/200	40kA*1	14	
	6600/110	200	PEC2-6FA/200	40kA*1	14	
	11000/110	200	PE11-10	40kA*3	25	
	11000/110	200*6	PE10-10	40kA*3	38	
	13200/110	200*6	PE10-15	31.5kA*4	38	
	22000/110	200	PE12-20	40kA*5	41	
33000/110	200	PE4-30	—	68		

Note: *1 Type PTFA-6, rated current 2A (provided with VT as standard) *2 BIL: Basic-impulse insulation level (full wave)
 *3 Type JR-10/5 (optional), rated current 5A *4 Type JR-10N/5 (optional), rated current 5A *5 Type JR-20/5 (optional), rated current 5A
 *6 400VA available

■ Types and ratings CT 11.5kV – 34.5kV

Illustration	Max. voltage (kV)	Primary current (A) Single ratio Double ratio	Secondary current (A)	Type	Withstand current (kA/1s)	Mass (kg)	Technical information				
 N33-142-12 CE3-10	11.5	50/5 75/5 100/5 150/5 200/5	— — 200-100 300-150 400-200	5	CE3-10	25	19 to 26	<ul style="list-style-type: none"> • Accuracy class: 1.0 • Rated overcurrent constant (n): n > 10 • Rated burden 15VA (Primary current 50A) 25VA (Primary current 75A) 40VA (Primary current over 100A) • Insulation level Dielectric strength: 28kV Basic-impulse insulation level: 90kV (full wave) 			
		300/5 400/5 500/5 600/5	600-300 800-400 1000-500 1200-600								
		750/5 1000/5 1200/5	— — —								
		1500/5 2000/5	— 2000-1000						5	CE5-10	25*
 N33-142-12 CE2-10 CE2-20	11.5	1500/5 2000/5 3000/5 4000/5	— 2000-1000 3000-1500 4000-2000	5	CE2-10	50	41 to 66	<ul style="list-style-type: none"> • Rated burden: 60VA • Insulation level: Dielectric strength: 28kV Basic-impulse insulation level: 90kV (full wave) 			
		5000/5	5000-2500						CE6-10	50	41 to 66
		23	50/5 75/5 100/5 150/5 200/5 300/5 400/5 500/5 600/5 750/5 1000/5 1200/5						— — 200-100 300-150 400-200 600-300 800-400 1000-500 1200-600 — — —	5	CE1-20
 N33-142-12 CE1-20	1500/5 2000/5	— 2000-1000	CE5-20	25*	62	<ul style="list-style-type: none"> • Accuracy class: 1.0 • Rated overcurrent constant (n): n > 10 • Rated burden: 60VA 					
	1500/5 2000/5 3000/5 4000/5	— 2000-1000 3000-1500 4000-2000	CE2-20	50	41 to 66	<ul style="list-style-type: none"> • Insulation level Dielectric strength: 50kV Basic-impulse insulation level: 125kV (full wave) 					
	5000/5	5000-2500	CE6-20	50	41 to 66						
 N33-142-12 CE4-30	34.5	50/5 75/5 100/5 150/5 200/5 300/5 400/5 500/5 600/5 750/5 1000/5 1200/5	— — 200-100 300-150 400-200 600-300 800-400 1000-500 1200-600 — — —	5	CE4-30	25	36 to 50	<ul style="list-style-type: none"> • Accuracy class: 1.0 • Rated overcurrent constant (n): n > 10 • Rated burden: 15VA (Primary current 50A) 25VA (Primary current 75A) 40VA (Primary current over 100A) • Insulation level Dielectric level: 70kV Basic-impulse insulation level: 170kV (full wave) 			

Note: * Withstand current of 25kA/2s type is also available

H.V. Distribution Equipment Instrument transformers

■ Dimensions, mm/CT

RC15-6C

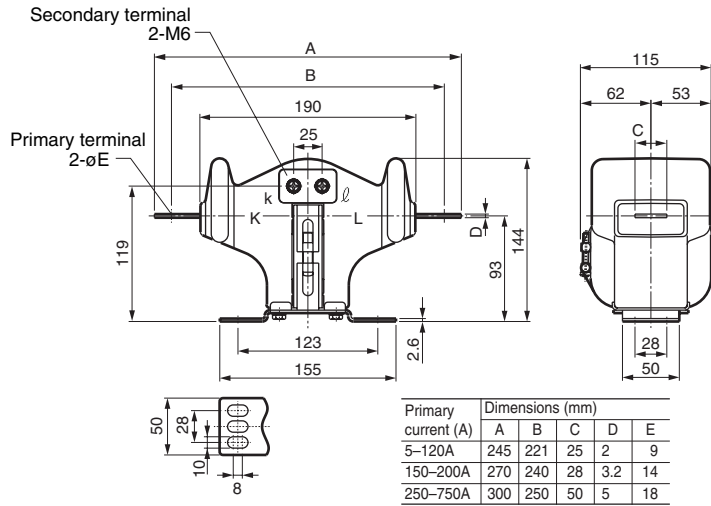

NCE2-6B

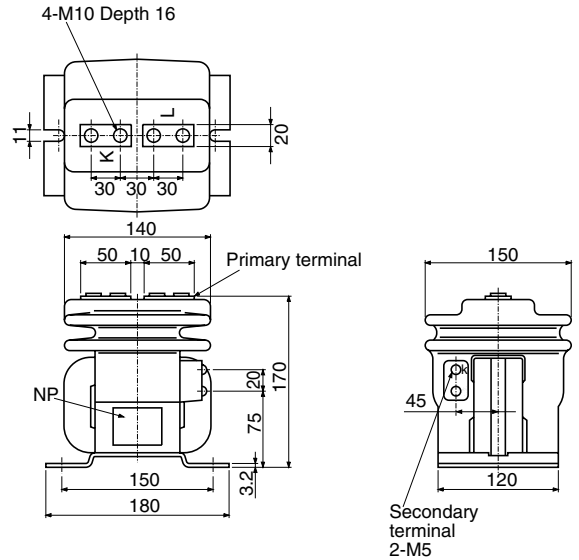

CEC1-6M

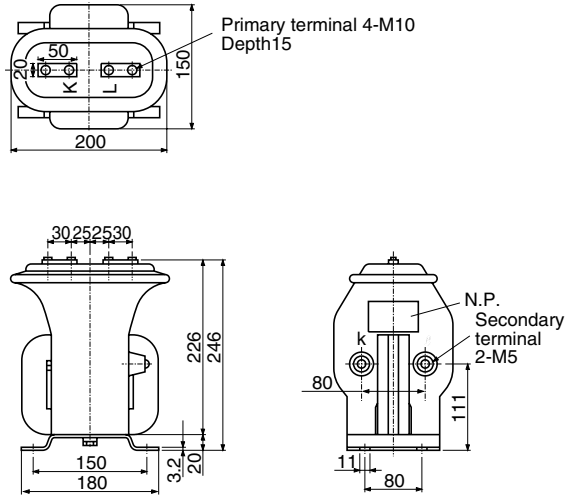

CEA1-6M

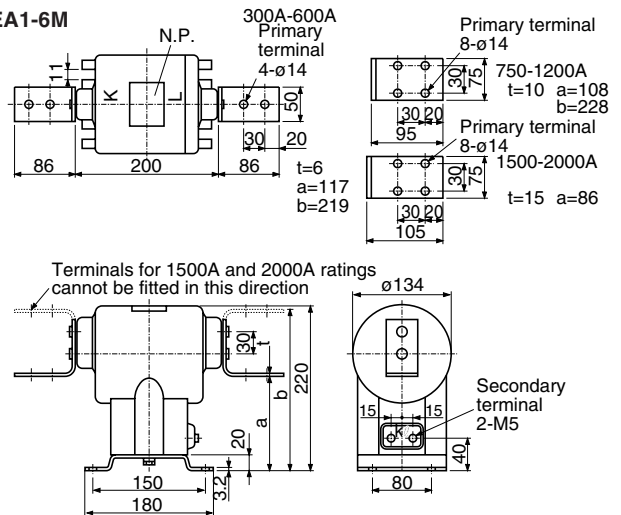

CE3-10

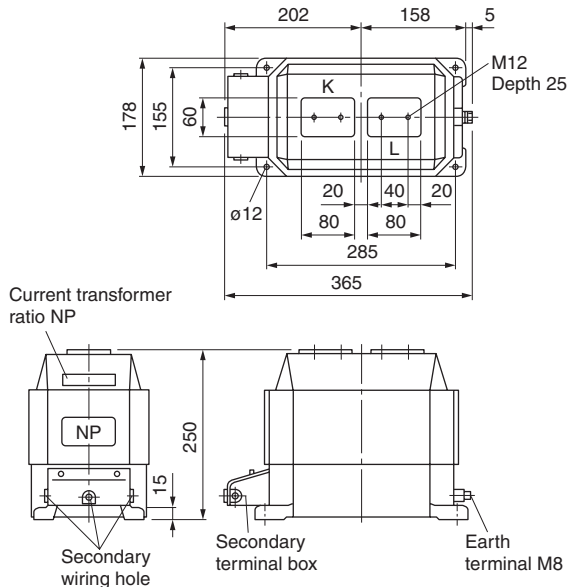

CE1-20

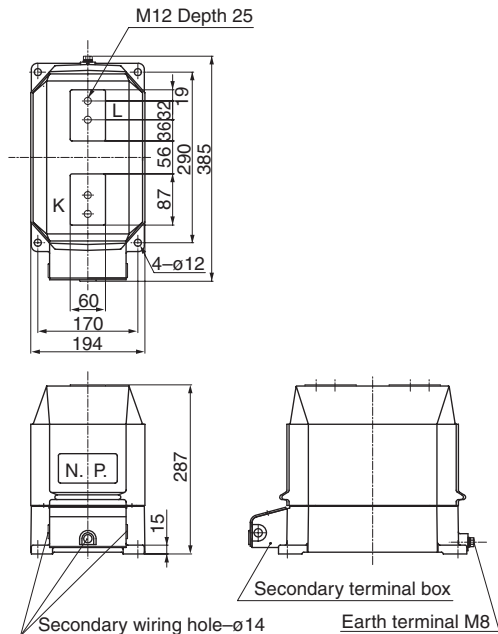

■ Dimensions, mm/CT

CE2-10, CE2-20

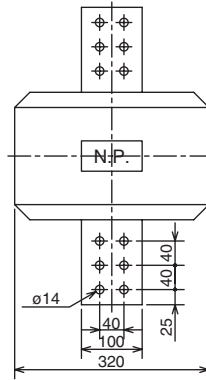

Primary current	Thickness of conductor T	No. of primary conductors
1500A	10	1
2000A, 2000-1000A	15	1
3000A, 3000-1500A	10	3
4000A, 4000-2000A	15	3

Standard	Terminal symbol				Terminal
	Primary	Secondary			
		Single ratio	Double ratio	Double core	
IEC BS	P1, P2	S1, S2	S1-S2-S3	1S1-1S2, 2S1-2S2	—
ANSI	H1, H2	X1, X2	X1-X2-X3	X1-X2, Y1-Y2	—
JEC	K, L	k, l	k1-k2-l	1k-1l, 2k-2l	g, h

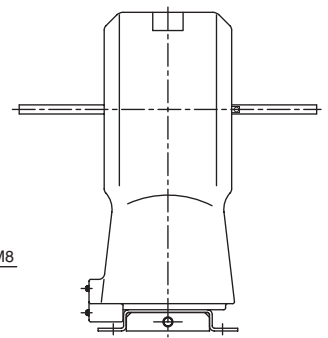
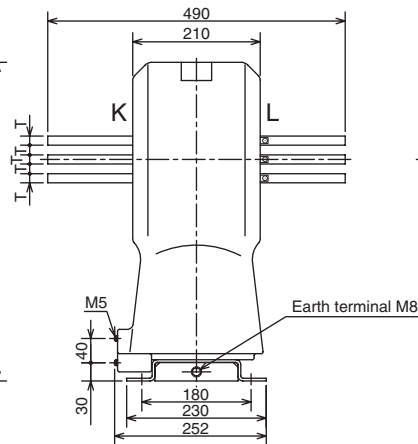
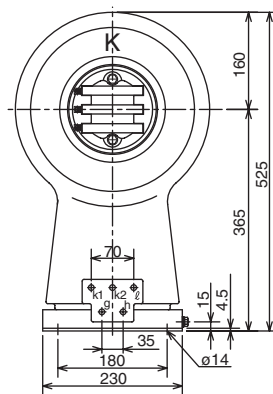
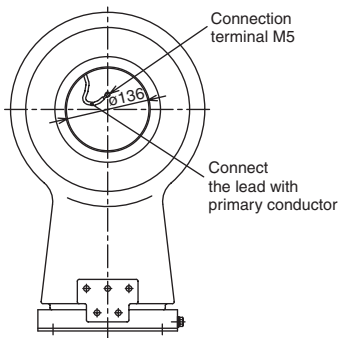

CE5-10, CE5-20

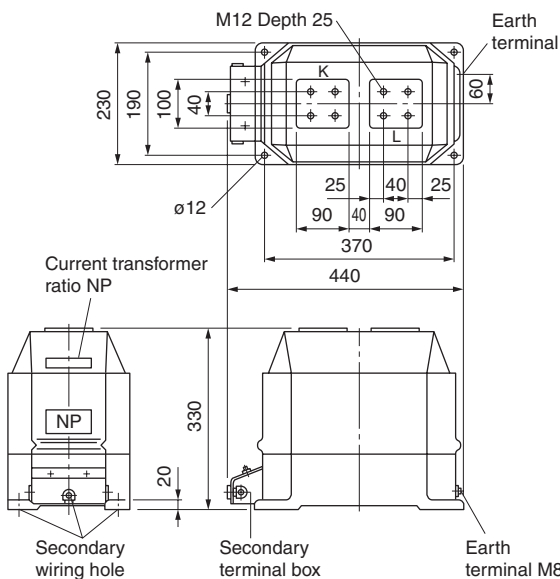

CE4-30

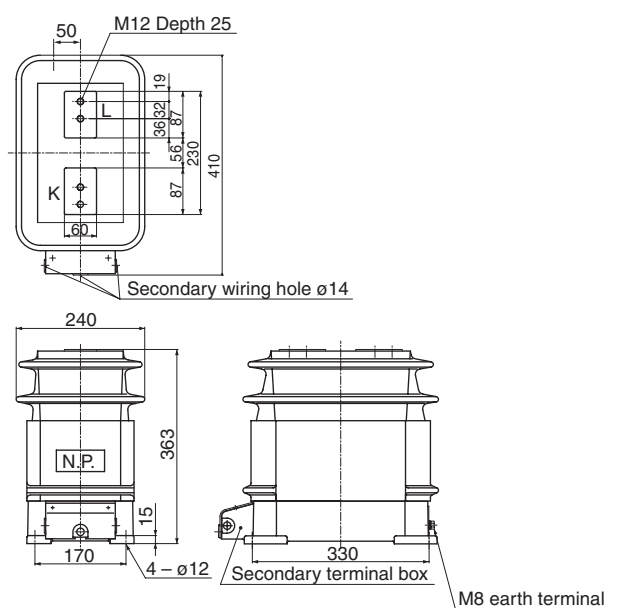

H.V. Distribution Equipment

Instrument transformers

■ Dimensions, mm/CT

CE6-10

CE6-20

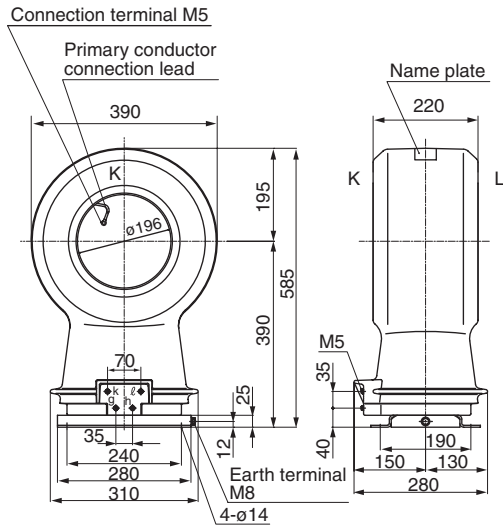

■ Dimensions, mm/VT (with fuse links)

NPE12-3FA
NPE12-6FA

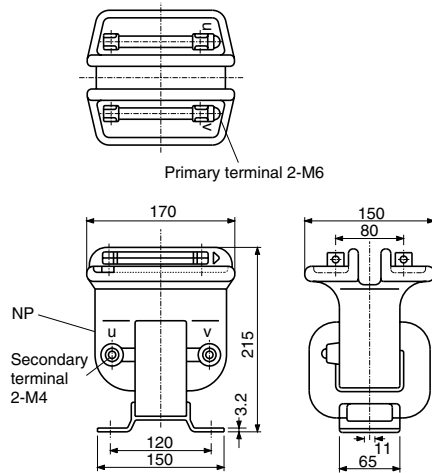

PEC2-3FA
PEC2-6FA

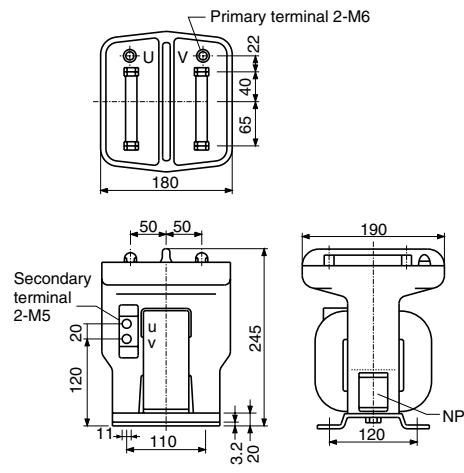

PE11-10

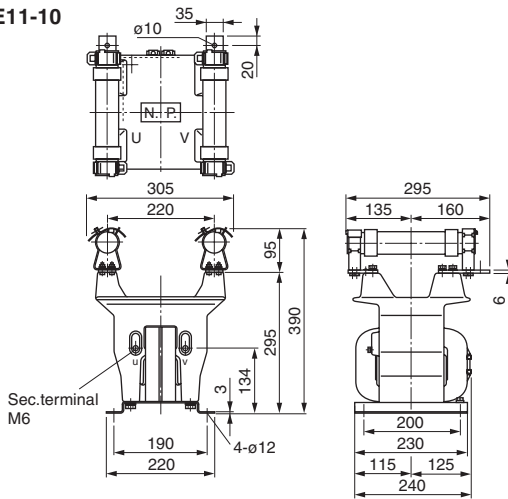

PE10-10
PE10-15

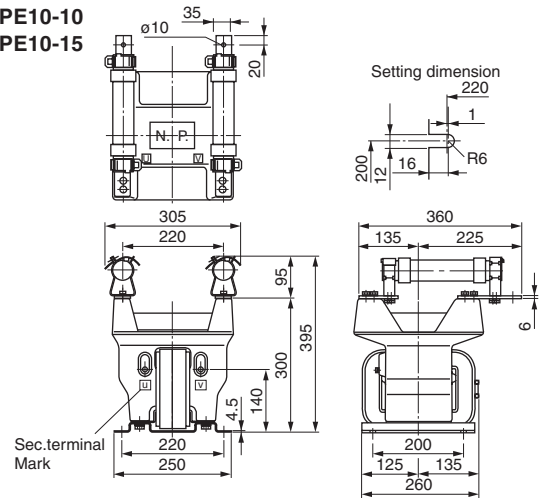

PE12-20

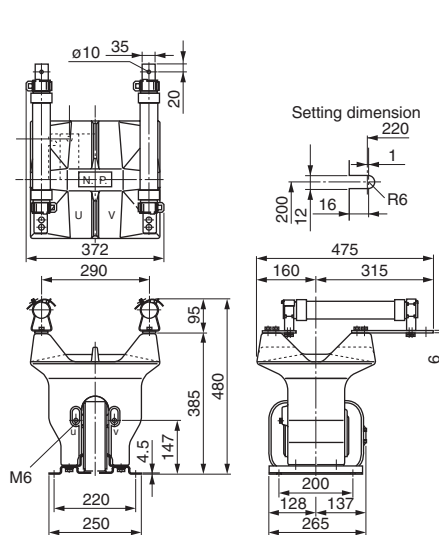

PE4-30

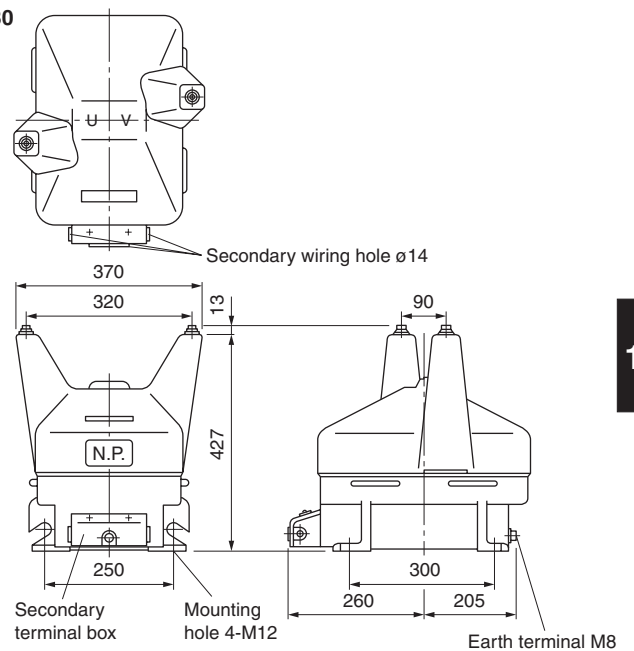

■ Split-toroidal type CT

Hole diameter (mm)	Primary current (A)		Secondary current (A)	Rated burden (VA)	Overcurrent constant (n)	Type	
	Single ratio	Double ratio					
65	200	—	5	15	n > 10	CED1/200	
	300	—		15		CED1/300	
	400	—		25		CED1/400	
	500	—		25		CED1/500	
	600	—		40		CED1/600	
	750	—		40		CED1/750	
90	200	—	5	15	n > 10	CED2/200	
	300	—		25		CED2/300	
	400	—		40		CED2/400	
	500	—		40		CED2/500	
	600	—		40		CED2/600	
	750	—		40		CED2/750	
		1000	—	5	40	n > 20	CED2/1000
		1200	—		40		CED2/1200
		1500	—		40		CED2/1500
	100	300	—	5	25	n > 10	CED3/300
		400	—		40		CED3/400
		500	—		40		CED3/500
600		—	40		CED3/600		
		750	—	5	40	n > 20	CED3/750
		1000	—		40		CED3/1000
		1200	—		40		CED3/1200
		1500	—		40		CED3/1500
		2000	—		40		CED3/2000
		3000	—		40		CED3/3000
		300	300–150	5	25	n > 20	CED3A/300
		400	400–200		40		CED3A/400
		500	—		40		CED3A/500
		600	600–300		40		CED3A/600
		300	300–150	5	40	n > 20	CED3B/300
130	400	400–200	5	40	n > 10	CED4/400	
	500	—		40		CED4/500	
	600	600–300		40		CED4/600	
		750	—	5	40	n > 20	CED4/750
		—	800–400		40		CED4/800
		1000	1000–500		40		CED4/1000
		1200	1200–600		40		CED4/1200
		1500	1500–750		40		CED4/1500
		2000	2000–1000		40		CED4/2000
		3000	3000–1500		40		CED4/3000

H.V. Distribution Equipment

Instrument transformers

■ Earthing voltage transformer EVT

Rated voltage (V)			Rated burden (VA)		Dielectric strength (kV, 1minute)		Impulse*1 (kV)	Type	Fuse
Primary	Secondary	Tertiary	Secondary	Tertiary	Primary	Secondary			
3300	110	110	3 × 100	3 × 500	2	2	45	GVE1-3FA-110/5G GVE2-3FA-110/5G	PTFA-6*2
		3	3 × 200	3 × 500	2	2			
6600	110	110	3 × 100	3 × 500	2	2	60	GVE1-6FA-110/5G GVE2-6FA-110/5G	
		3	3 × 200	3 × 500	2	2			
11000	110	110	3 × 200	3 × 200	2	2	90	GPE9-10 GPE8-10 GPE7-10	JR-10/5*3 JR-10/5*3 JR-10/5*3
		3	3 × 200	3 × 200	2	2			
			3 × 200	3 × 200	2	2			
13200	110	110	3 × 200	3 × 200	2	2	95	GPE7-15	JR-10N/5*3
22000	110	110	3 × 200	3 × 200	2	2	125	GPE12-20	JR-20/5*3
22000	110	110	3 × 200	3 × 200	2	2	150	GPE13-20	JR-20/5*3
33000	110	110	3 × 200	3 × 200	2	2	170	GPE21-30	—

Note: *1: 1.2 × 50μs *2: Provided *3: Optional

■ Dimensions, mm

● Toroidal-type ZCT

ZCE1A, 2A, 3A, 4A

Type	d	X	Y	Z	H	W	A	B	Mass (kg)
ZCE1A/200	65	140	75	180	110	90	40	25	4.0
ZCE2A/400	80	160	90	210	130	90	40	25	5.6
ZCE3A/750	100	185	105	248	155	120	60	35	8.4
ZCE4A/1200	125	214	120	287	180	120	60	35	12.0

Dimensions for reference only. Please confirm before construction begins.

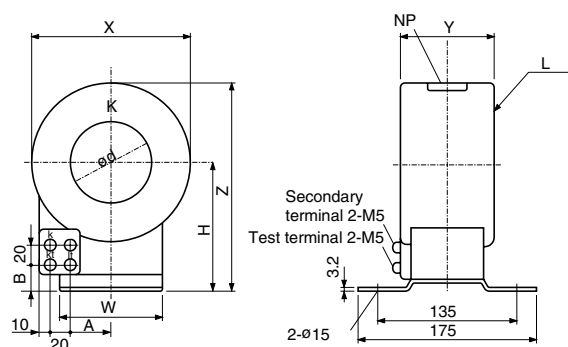

ZCE5A/3000

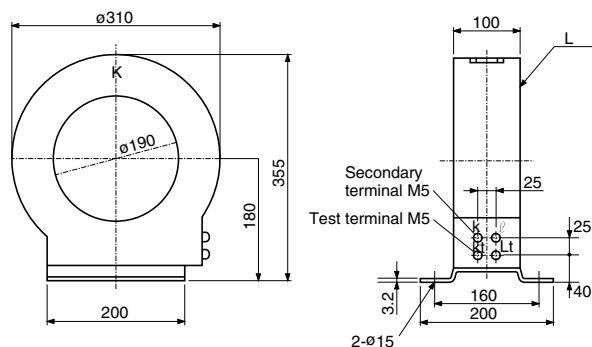

Mass: 14kg

■ Dimensions, mm

● Split-toroidal type CT/ZCED

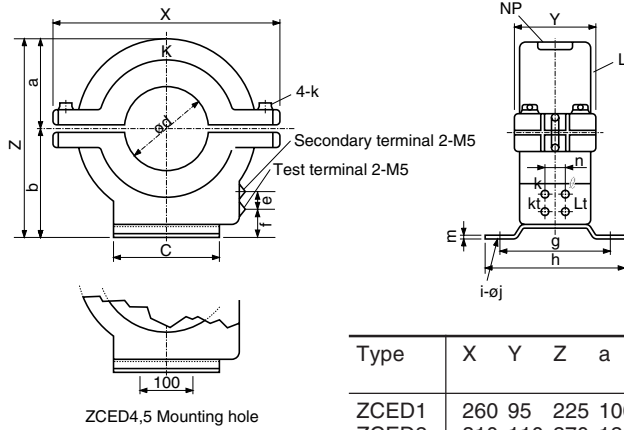

Type	X	Y	Z	a	b	c	d	e	f	g	h	i	j	k	m	n	Mass (kg)
ZCED1	260	95	225	100	125	130	65	27	30	135	175	2	14	M10	3.2	27	15
ZCED2	310	110	270	120	150	150	90	27	40	135	175	2	14	M10	4.5	27	20
ZCED3	340	110	295	130	165	150	100	30	40	135	175	2	14	M10	4.5	27	25
ZCED4	380	140	350	155	195	200	130	30	55	200	250	4	18	M10	6	30	30
ZCED5	460	150	405	185	220	200	150	30	55	200	250	4	18	M12	6	30	52

Dimensions for reference only. Please confirm before construction begins.

● Split-toroidal type CT/CED

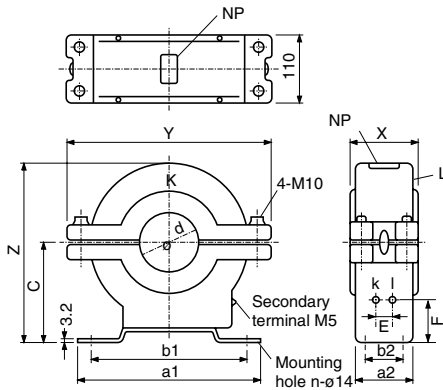

Type	X	Y	Z	d	a ₁	a ₂	b ₁	b ₂	c	E	F	n
CED1	95	260	225	65	260	80	220	—	125	27	57	2
CED2	110	310	285	90	300	90	260	—	165	27	82	2
CED3	110	340	295	100	300	95	260	—	165	27	67	2
CED3A	200	340	295	100	300	190	260	120	165	50	65	4
CED3B	250	340	295	100	300	240	260	120	165	50	65	4
CED4	125	350	305	130	300	110	260	70	165	50	50	4

Dimensions for reference only. Please confirm before construction begins.

● Earth voltage transformer VT/GVE1, GVE2

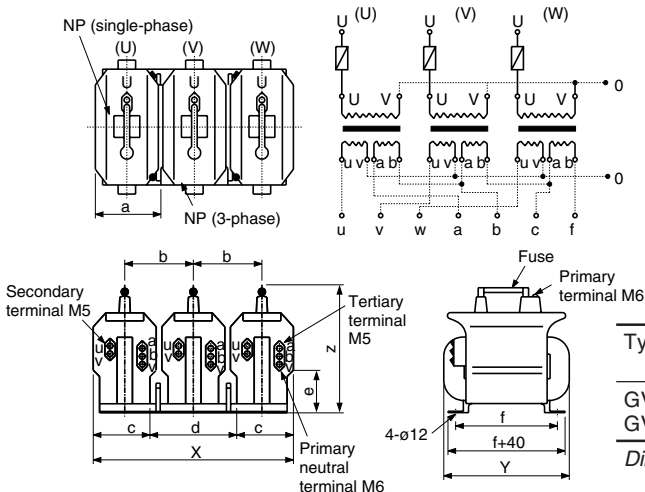

Type	X	Y	Z	a	b	c	d	e	f	Mass (kg)
GVE1	428	265	284	136	146	104	220	90	220	59
GVE2	476	305	300	152	162	128	220	100	220	82

Dimensions for reference only. Please confirm before construction begins.

H.V. Distribution Equipment

Instrument transformers

■ Dimensions, mm

● Earthing voltage transformer VT (with fuse links) GPE9-10

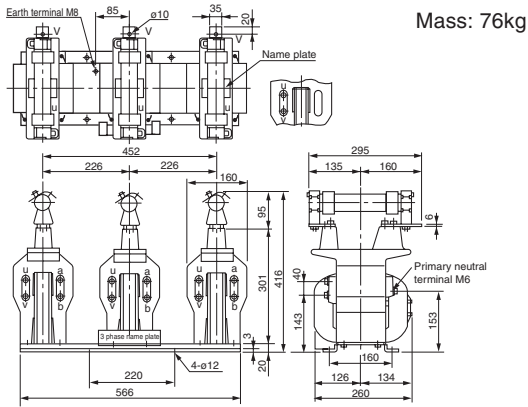

GPE12-20

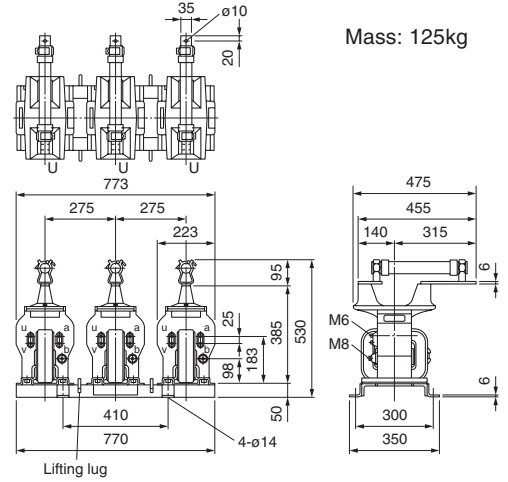

GPE8-10

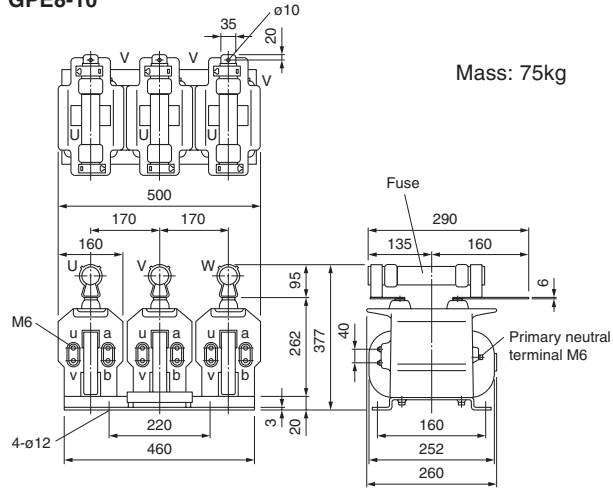

GPE13-20

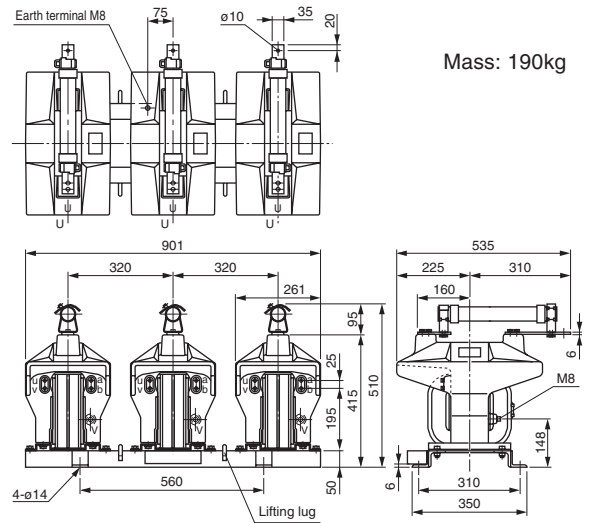

GPE7-10, GPE7-15

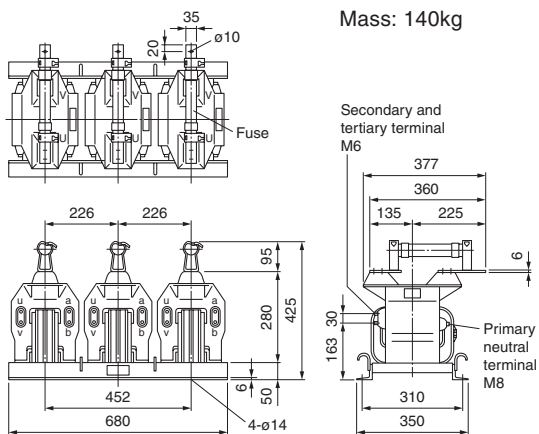

GPE21-30

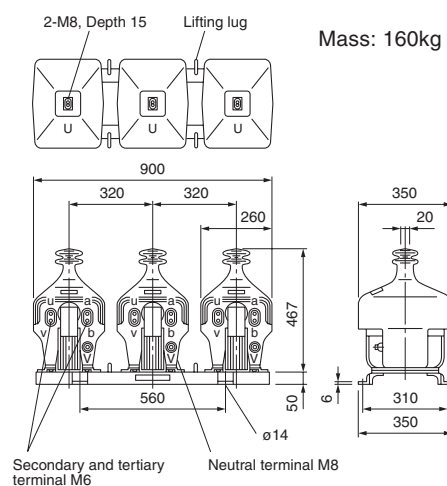

Catalog Disclaimer

The information contained in this catalog does not constitute an express or implied warranty of quality, any warranty of merchantability or fitness for a particular purpose is hereby disclaimed.

Since the user's product information, specific use application, and conditions of use are all outside of Fuji Electric FA Components & Systems' control, **it shall be the responsibility of the user to determine the suitability of any of the products mentioned for the user's application.**

One Year Limited Warranty

The products identified in this catalog shall be sold pursuant to the terms and conditions identified in the "Conditions of Sale" issued by Fuji Electric FA with each order confirmation.

Except to the extent otherwise provided for in the Conditions of Sale issued by Fuji Electric FA, Fuji Electric FA warrants that the Fuji Electric FA products identified in this catalog shall be free from significant defects in materials and workmanship provided the product has not been: 1) repaired or altered by others than Fuji Electric FA; 2) subjected to negligence, accident, misuse, or damage by circumstances beyond Fuji Electric FA's control; 3) improperly operated, maintained or stored; or 4) used in other than normal use or service. This warranty shall apply only to defects appearing within one (1) year from the date of shipment by Fuji Electric FA, and in such case, only if such defects are reported to Fuji Electric FA within thirty (30) days of discovery by purchaser. Such notice should be submitted in writing to Fuji Electric FA at 5-7, Nihonbashi Odemma-cho, Chuo-ku, Tokyo, Japan. The sole and exclusive remedy with respect to the above warranty whether such claim is based on warranty, contract, negligence, strict liability or any other theory, is limited to the repair or replacement of such product or, at Fuji Electric FA's option reimbursement by Fuji Electric FA of the purchase price paid to Fuji Electric FA for the particular product. **Fuji Electric FA does not make any other representations or warranties, whether oral or in writing, expressed or implied, including but not limited to any warranty regarding merchantability or fitness for a particular purpose.** Except as provided in the Conditions of Sale, no agent or representative of Fuji Electric FA is authorized to modify the terms of this warranty in writing or orally.

In no event shall Fuji Electric FA be liable for special, indirect or consequential damages, including but not limited to, loss of use of the product, other equipment, plant and power system which is installed with the product, loss of profits or revenues, cost of capital, or claims against the purchaser or user of the product by its customers resulting from the use of information, recommendations and descriptions contained herein. The purchaser agrees to pass on to its customers and users, in writing at the time inquiries and orders are received by buyer, Fuji Electric FA's warranty as set forth above.

Caution "Safety precautions"

- Operate (keep) in the environment specified in the operating instructions and manual. High temperature, high humidity, condensation, dust, corrosive gases, oil, organic solvents, excessive vibration or shock might cause electric shock, fire, erratic operation or failure.
- Follow the regulations of industrial wastes when the product is to be discarded.
- The products covered in this catalogs have not been designed or manufactured for use in equipment or systems which, in the event of failure, can lead to loss of human life.
- If you intend to use the products covered in this catalog for special applications, such as for nuclear energy control, aerospace, medical, or transportation, please consult our Fuji Electric FA agent.
- Be sure to provide protective measures when using the product covered in these catalogs in equipment which, in the event of failure, may lead to loss of human life or other grave results.
- Follow the directions of the operating instructions when mounting the product.

11

INDIVIDUAL CATALOG

from D&C CATALOG 19th Edition Revised

Fuji Electric FA Components & Systems Co., Ltd.

5-7, Nihonbashi Odemma-cho, Chuo-ku, Tokyo, 103-0011, Japan

URL <http://www.fujielectric.co.jp/fcs/eng>

Information in this catalog is subject to change without notice.



Printed on 100% recycled paper using soy-based ink